

SHRINKING-WRAPPING MACHINE

OPERATION & MAINTENANCE MANUEL

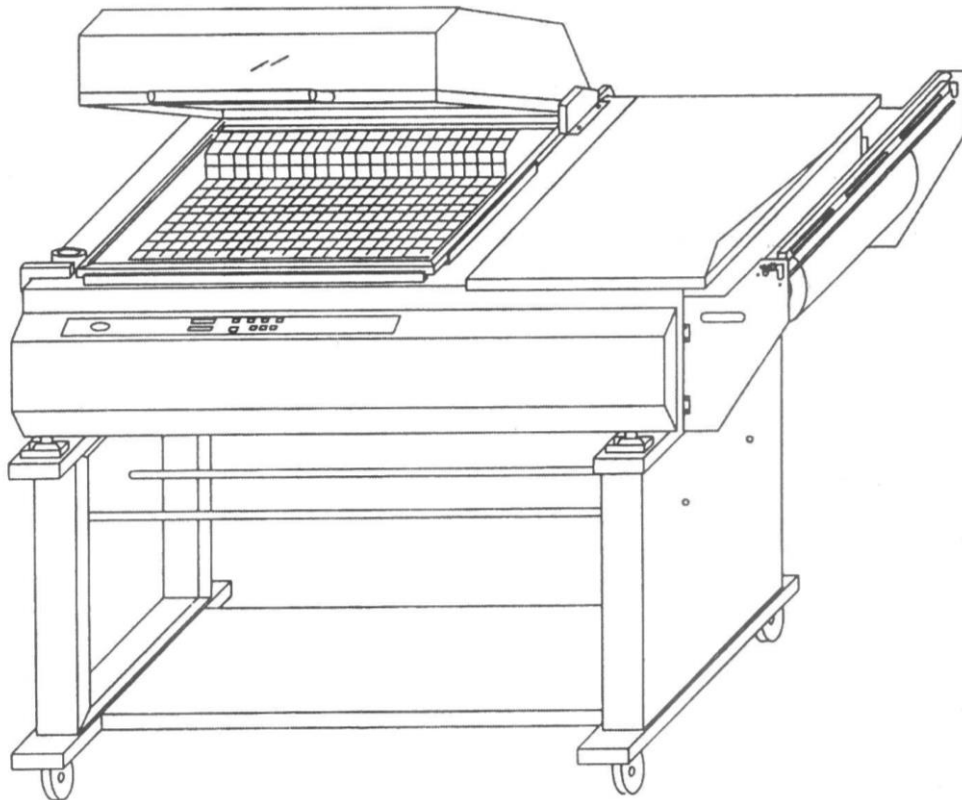

SAFETY INFORMATION

Before attempting to service or use this machine carefully read this instruction manual.

Please pay particular attention to features showing the WARNING SYMBOL:



1. DO NOT replace any safety parts of different Specifications
2. DO NOT use the machine in an atmosphere of high humidity
3. Metal parts at the back of the machine close to the heater box .will become hot during machine operation. There parts are marked with an appropriate symbol –staff should take care not to touch these parts when the machine is operating.
4. Keep the instruction manual available at all times and ensure that your operators are fully familiar with the machine and its controls and method of operations. The machine will then give your long and trouble free service in safety.
5. All technical queries must be refer to US. No liability is accepted for personal injury or consequential loss suffered as a result of unauthorized repair/alterations, or failure to use the machine strictly in accordance with these instruction
6. Remember that if the machine is being moved ,or film rolls weighting in excess off 15 kgs are being handled-use at least 2 peoples
7. The machine must be protected by a 25 amp fuse. The supply MUST BE EARTHED
8. Shut off all electrical power after machine operation or servicing machine.

TABLE OF CONTENTS

Machine description	1
Packaging	2
Machine assembly	3
Specification	4
Controls	5
Setting –up procedure	6
Operation	7
General maintenance	8
Routine maintenance	8
Trouble shooting	9
Parts list and exploded views	10~21
Electrical schematic	22

MACHINE DESCRIPTION

Our machine is a manually operated shrink wrapping machine for use with PVC or polyolefin shrink films

It can be used either to make loose bags, or to shrink the film tightly around your products by circulating heated air inside the hood.

Suitable for use with single products or for collation of several products in one packaging. The shrinking of the film can be carried out at the same times as the cutting and is achieved by the circulation of hot air forced around the package

notice: 

THE FOLLOWING SHOULD NOT BE USED WRAP:

Liquid and/or gelatinous products if not contained in another package

Anything that could damage the machine or constitute a danger to the health of the operator(for example, acids, corrosive substance, salt)

Explosive products;

Highly inflammable products;

Liquid or moist products, unless contained within other packaging;

Loose or granular products;

Notice: 

If you are wrapping foodstuffs with direct film contact you. Should always ensure that you use a film approve for direct contact with that type of food

PLEASE PAY PARTICULAR ATTENTION TO THE FOLLOWING

LIMITS OF USE

The machine must not be used in the following location: open-air environments and /or those exposed to the elements, environments containing steam, fumes corrosive and/or abrasive dusts, environments with fire or explosion hazards, and in any case wherever the use of fireproof components is required The electrical equipment operates correctly within an ambient temperature range of +5°C to 40°C and with relative humidity limits of less than 50% at 40°C and less than 20% at 20°C

The machine is not suitable for operation in the presence of ionizing and other kinds of radiations(X-rays ,lasers ,microwaves ultraviolet-rays)

The machine must be stored at temperature between-5°C and 55°C

PACKING

Machine is film wrapped for protection and packed for transport in corrugated sleeve and top, and secured to a pallet.

Particular care must be taken in opening the case not to damage the machine

The MACHINE STAND is packed in separate corrugated case

The machine packaging contains:

- the machine body
- the film reel carrier
- the film shaft with 2 cones
- plastic bag with spare parts
- maintenance manual



Care must be taken in unpacking the machine not to damage the plastic hood!

please pay attention to the following, If you had purchased the machine stand

The machine stand case contains:

- 1base section
- 2upright sections
- 3basketry bracket shaft
- 1waster film basketry
- plastic bag containing nuts/bolts for stand assembly

Optional bag containing:

- 1 spare sealing wire;(7-05000-250)
- sponge strip; 1(7-05000-130)
1 (7-05000-131)
- 2spring; (2201411055)
- spare roll of Teflon tape
297F0074
- Manual for installation, use and
maintenance

Tools parts:

- 1 screwdriver
- 1 2.5mm Allen wrench
- 1 3mm Allen wrench
- 1 4mm Allen wrench
- 1 5mm Allen wrench
- 1 6mm Allen wrench

MACHINE ASSEMBLY

STAND (see also Fig.1)

---Secure the 4castors to the stand base section using the nuts provided, and position the BRAKED castors at the FRONT of the stand

-Next assemble the UPRIGHT sections to the base unit, Be sure to use the STRENGTHENING WASHERS when fitting the upright sections

--Next assemble the basketry bracket and basketry

--The BASE section is a useful storage area for spare film rolls

MACHINE BODY(see also Fig2)

--Put the machine on the stand (ensuring that the adjustable leveling feet locate in the cups on the UPRIGHT sections).OR the machine on your bench if no machine stand has been purchased.

NOTE: do not hold it by the handle of the hood or the film holder unit (it is advisable to use two people for this operation)

-Slide the reel carrier assembly from the back of machine forwards, into the twin slides, until the carrier extends about 300mm to the front of the machine body ,the reel carrier will have to be “eased” past the stop at the rear of slides, the travel of the reel carrier is now limited front and rear

--Cut the adhesive tape holding the hood closed ,and position the wire package tray using the 2 sets of hoods at the chamber, and fitting the 2thumb screws to match at the front of the chamber.



--Ensure that nothing remains loose in the base of the chamber-it could seriously damage the fans

--The hood should remain in the OPEN positions, if necessary adjust by means of the torsion bar adjustment bolt on the back of the machine

--Fit the roll of center-folded film centrally on the film shaft and lock in position using the cones and the Allen key provided, the folded edge of the film is fitted to the rear of the machine-open edge to the front.

--Pull the end of the film through the 2 rods carrying the perforator wheels. Over the top roller ,and around the film separation table.

SPECIFICATIONS
OVERALL DIMENSIONS

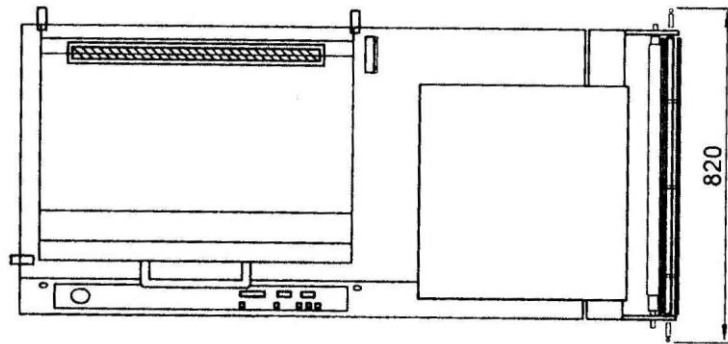
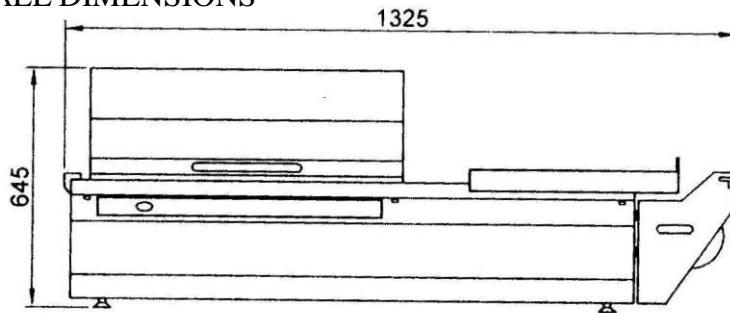

SPECIFICATIONS

- Weight of machine (without stand): 85kg
- Height of working table (on stand) 370mm
- The machine height of working incl. stand 910mm
- Dimensions of sealing:420×550
- Power:3.77kw
- Voltage: 230v/1-phase

- packaging capacity:
- min: A×B×C 50×50×1mm
- max: A×B×C 520×390×250mm

NOTES:B+C must never exceed 550;it is not possible to create packages with the maximum dimension A×B×C,

- film to be used for packaging :center-fold sealing film, thickness 60 gauge.
- dimensions(D-F-E) 600×250×75mm

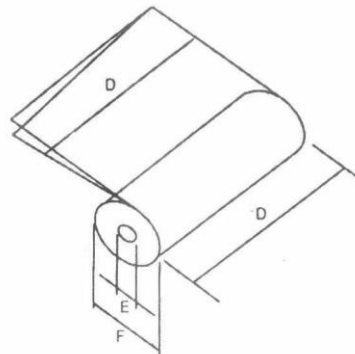
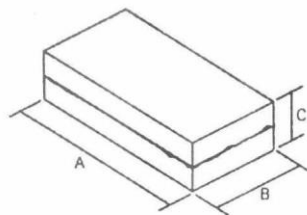

CONTROLS

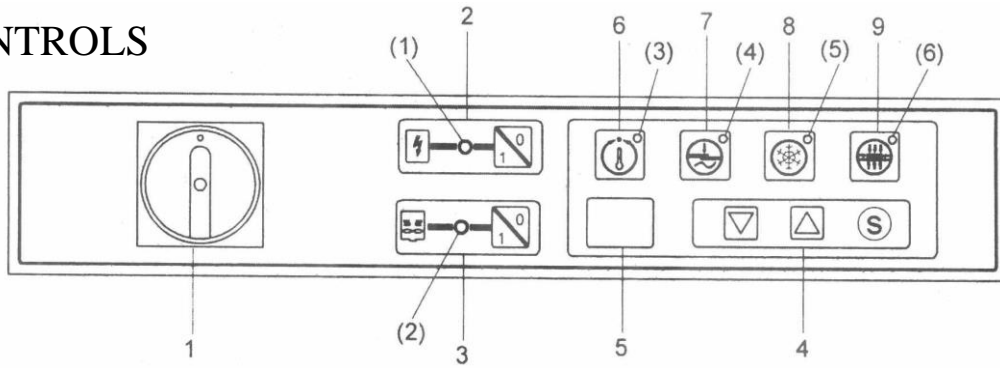

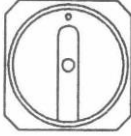
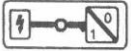
- 1.  MAIN SWITCH
- 2.  START SWITCH

- 5.  DIGITAL READOUT
It shows the value of the every time setting.

Press the key , the indicator lamp(1) will light, The machine starts heating and the machine is only for sealing .in any situation, press the key to make lamp go out, you can stop the machine

- 3.  SHRINK SWITCH

If indicator lamp(2)lights,(this can be gotten by pressing the key).the machine can seal and shrink film. This key has the function of maintaining working mode under any conditions

- 4.  SETTING KEY

Though this key, seal temperature, seal time, cooling time and magnet closed time can be adjusted

(S) CHOOSING KEY
The lamp(3),or (4), or (5), or (6)will light in orange when you press the key every time

-  VALUE INCREASING KEY
-  VALUE DECREASING KEY

NOTE: the above two keys works When digital readout flashes.

- 6.  HEATING INDICATOR
When the machine temperature does not reach the setting temperature, the lamp(3)will light in red ,The lamp will light in green till the machine temperature reach the setting temperature which indicate you can start to operate the machine

- 7.  SEALING INDICATOR
The lamp (4)light in green while the machine is operated

- 8.  COOLING INDICATOR
The lamp(5)will light in green while the film is cooled after cutting

- 9.  SHRINKING INDICATOR
The lamp(6)will light in green while the machine is shrinking.

SETTING –UP PRODEDURE

1. Set the MIAN SWITCH to position “ON”.
2. Press the button of START/STOP to make the lamp light
3. Set the SEAL TIMER .The digital readout 5 shows the value of the seal time (see page 5) Press the choosing key the second time. 5 will flash. Then using ∇ or \triangle to adjust the time to suitable value. Pull the leading edge of the film into the chamber and cross the sealing blade. close the hood and check if the film cuts and seals cleanly. If not , increase the setting of the SEAL TIMER until a good seal and clean cut are obtained. Always set this timer at lowest value where good sealing occurs .
- 4 Set machine in “SEAL&SHRINK” mode . the digital readout 5(see page 5)will show the preset temperature .Press the choosing key the first time ,5will flash ,Then using ∇ or \triangle to adjust the temperature to suitable setting for your film-usually 03-05 for PVC film07-09for POF films Operating experience will soon tell you the optimum for the film you use.

You are told about the preset temperature as following:

- 00- the temperature is 0°C
- 01- the temperature is 102°C
- 02- the temperature is 114°C
- 03- the temperature is 126°C

N- the temperature is $90+12 \times N^{\circ}\text{C}$

5. The digital readout5 (see page5)show the preset magnet closed time. Press the choosing key the fourth time,5 will flash , The using ∇ or \triangle to adjust the time. Next, close the hood , the magnets will clamp the hood whilst the fans circulate heated air. The hood whilst the fans circulate heated air. The hood will open automatically when the sequence is finished. Again, operating experience will quickly show Whether longer or shorter magnet/shrink cycle

Times are required to successfully shrink wrap Your produces.

- 6 Press the choosing key the third time (see page5) 5 will flash, Then using ∇ or \triangle to adjust the cooling time: show:00 means :sealing and shrinking is working at the same time. show 0 1means :starting shrinking immediately after sealing show N ($2 \leq N \leq 9$)means: when the sealing is finished, start shrinking after (N-1) seconds(cooling time).Operating experience will soon tell you the shrink mode(cooling time) for the film you use

The REEL and FILM DIVIDING TABLE slide forwards and backwards to suit the size of film and product being used. The WIRE PRODUCT TRAY can be raised or lowered inside the chamber using the hooks at the back and the 2 screws at the front. The tray should normally be positioned so that the seal appears about half-way up the side of the product

Micro Switch Striker Adjustment

The adjustable pin which operates the machine micro-switch has been pre-set and its adjustment locked by means of two nylon nuts. If for any reason this adjustment should be lost or altered during operation then the striker should be reset GENTLY to strike the micro-switch, IF THE MICRO-SWITCH STRICKER IS SET TOO LOW IT WILL DAMAGE THE OPERATING MICRO-SWITCH

OPERATION

The way to thread film:

Adjust the position of the connector shaft through pulling the sphere-type handle(the black sphere on the two side of connect shaft) to locate it at the lowest point of the “”groove Thread the film across between the rubber roller and the connector shaft pass the lower and upper edge of the film under and over separator respectively

In according with customers 's request ,you can adjust click pulley to stitch the film.If so , please move the connector shaft to the right of the “” groove to make spike press the rubber roller closely

Draw the leading edge of the film from Right to Left into the chamber area and cross the sealing blade. Ensure the top and bottom leaves of film around the dividing table are equal in length, and operate the hood to produce a seal on the Left –hand end of the film Remove the waste film-cut off by this operation from inside the chamber

Place your product on top of the dividing table and inside the film –against the fold at the back. and the seal at the Left–hand side Draw product and film into the chamber and place approximately 10mm or 15mm from the front and side seals .Operate the hood and the shrink/seal process is carried out automatically with the hood opening on completion of the cycle.

If the film is not fully shrunk –increase MAGENT TIMER and /or TEMPERATURE until good results are obtained.

If the film burns or punctures-reduce TEMPERATURE and/or MAGENT TIMER until good results are obtained.

FILM SIZE/ADJUSTMENT

Select a suitable film width for your Product (-usually WIDTH OF PRODUCT (front To back) and HEIGHT OF PRODUCT + about 75mm), Fit the film on the reel carrier with the folded side to the rear of the machine .and thread as described previously. The front OPEN side of the film should be about 50mm Over the front seal blade, and the DIVIDING TABLE should be positioned so that inside the film it is about 20mm from the folded edge.

DO NOT attempt to seal and shrink if there is any tension on the film as the hood is closed -the pack will split open as it shrinks. ALWAYS allow the film to be relaxed as the seal takes place.

If the film **BALLOONS** and does not shrink fully around your product-then the machine is making too good a seal !Use one or both sets of perforator wheels on the reels carrier during the shrink process



TAKE CARE –THE PERFORATOR WHEELS HAVE SHARP SPIKES which are behind the film during operation but which are **EXPOSED DURING ADJUSTMENT AND FILM THREADING**

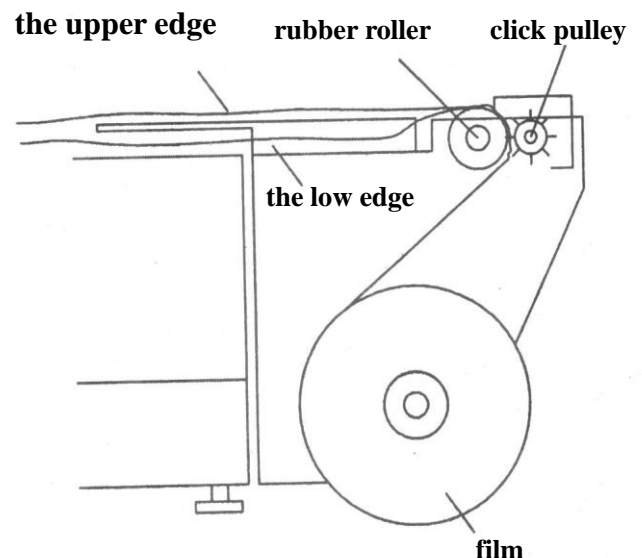

GENERAL MAINTENANCE



Operations to be carried out by the machine operator.

The machine operates with plastic films which may leave deposits on the sealing blade and so effect quality

The sealing blades:

Keep the sealing blades clean by using a rag or NON-METALLIC scraper (or thumb –nail!)and keep the Teflon tape on the both top jaw clear in same way .Apply a SILICONE LUBRICANT spray to both top and Bottom jaws, several times a day, for easier And cleaner machine operation.

Transparent hood:

The transparent machine hood may be kept clean with glass polish or similar-DO NOT USE SOLVENT CLEANERS

CAUTION IN OPERATION

To in order to make your packaging products Sealed and shrunk completely, you can operate The machine as following:

1.To in order to shrink the product, you must make the chamber to be hot by opening and closing the hood repeat when you start or you are asked to operate again in the case of your operation is interrupted.

2.the experience is important to seal and shrink .you will know the appropriate sealing time\shrinking temperature and operating frequency by operating the machine continually.

3 Yu will be known that only have a good product sealer, your product will be shrunk completely. So when you operate the machine for sealing or sealing and shrinking, you can close the hood with your high hand, almost at the same time, pull the film by the waste film to move from left to right after sealing time is finished.

ROUTINE MAINTENANCE

It is advisable to use two qualified people for Maintenance .



BEFORE ATTEMPTION ANY MAINTENANCE TURN MAIN SWITCH OFF AND DISCONNECT POWER SUPPLY!



CAUTION HOT!! CAUTION HOT!! SEALING BLADE REPLACEMENT

Undo the screws on the expansion blocks and the central knuckle. Remove the broken seal blade and fit new one after cleaning the sealing base of any deposits/dirt. Apiece of Teflon tape around the corner of the wire helps seal quality and insulation of heat. Introduce the end of the front seal blade 15mm inside the plunger to the RIGHT I order to compress the spring .then tighten the screws ,Repeat the process with the tighten the screws on the center buckle.

SILICONE RUBBER REPLACEMENT

The silicone rubber strip inside the top jaw must remain flat and undamaged .if it is necessary to replace the rubber, pull the damaged strip out and clean away any silicone adhesive. Replace the rubber strip using fresh silicone adhesive sparingly. Leave to cure overnight.

REGULAR REPLACEMENT of the TEFLON BARRIER TAPE will increase the life of the Silicone rubber.

TEFLON BARRIER TAPE REPLACEMENT

Remove old Teflon barrier tape before it burns or marks bodily. The tape is supplied on a roll, with self-adhesive backing. Simply cut to length .Remove backing protection and stick in place.

TROUBLE SHOOTING

THE HOOD WON'T STAY OPEN

Torsion bar out of adjustment? Torsion bar broken ?

Solution: Replace the torsion bar

THE HOOD WON'T STAY OPEN COMPLETELY

Solution: Tighten the special screw.

FAILURE TO CUT FILM CLEANLY

Sealing blades dirty? Seal time too low?

Solution: Check the clamps of the sealing wire and make sure that the latter is not broken, replace if interrupt.

Adjust according to the type of film.

SEAL SPLITTING

Seal timer too high? Film under tension during seal?

FAN WON'T CYCLE

Operating micro-switch out of adjustment or broken? Toggle switch set to seal only? motor condenser of fan motor faulty?

SEALING BLADE LEAVES SEALING BASE

Worn sealing base? Seal time too low?

Operator not detaching film before the hood opens?

THE PACKAGING IS AWOLLEN AFTER SHRINK-WRAPPING

The film used is not micro-perforated?

Solution: Make the film pass through the Micro-piercing device of the machine.

ELECTRO-MAGNETS WON'T CLAMP

Magnet pole pierce pads out of adjustment? Magnet timer set too low/defective?

INCOMPLETE SEAL

Solution: Check sealing blades and Teflon tape for cleanliness. Clean and lubricant

With silicone. Check Teflon tape for burning

And/or wear-

Replace if necessary. Check silicone rubber in top jaw(beneath Teflon tape).If cut or damaged ,replace.

HEATERS NOT OPERATING

Toggle switch set to seal only?

Temperature controller set low?

Temperature controller /thermocouple/elements defective

MACHINE NOT –BUT NO SHRINK

Film type/grade correct?(some plastic film do not shrink). Shrink temperature incorrect for this type of material? Fan impeller

loose on motor shaft?

The mistake cue for PC board:

- 1.E1 detect abnormal temperature sensors showed :
Said sensor signal not access, circuit breaking
Where : check processing break, and then a good job.
- 2.Show for E2, 20 minutes at 80 ° C below the temperature to at least one year.
Reasons : use of a temperature sensor short circuit, or from the sensor, which was less than the actual signal.
- 3.For the E3 show, at 35 minutes, the temperature is consistently below target temperature.
Reasons : heater fault or sensor from the sensor, but the actual temperature is over 80 ° C.