

Bulk Bag Loading & Unloading Systems

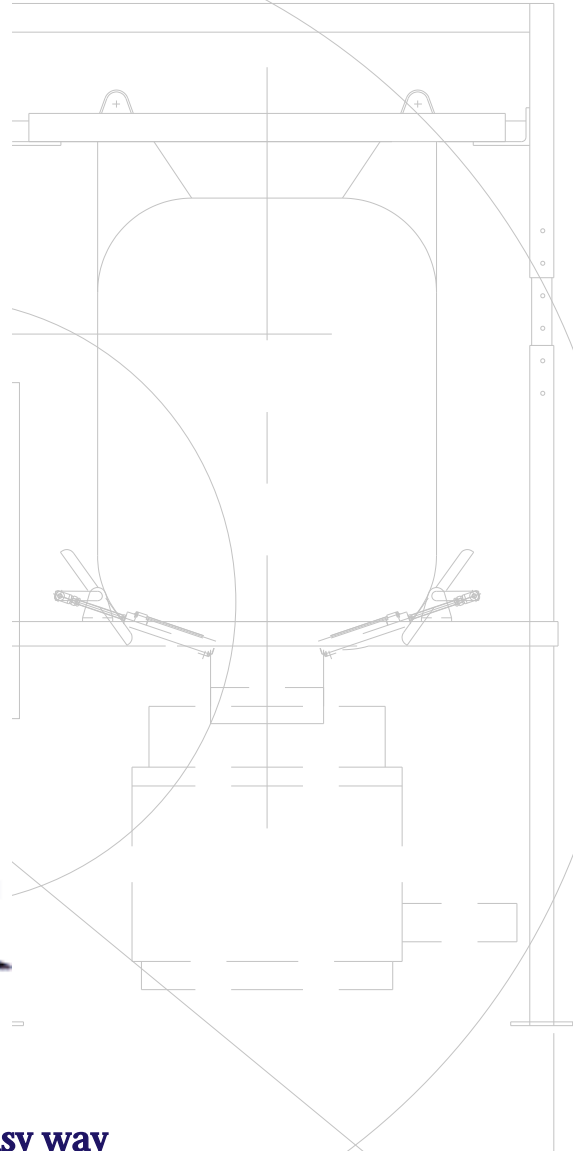

**An innovative and easy way
to load / unload Bulk and Semi Bags**



KLAUSEN PROCESS MACHINERY PTY. LTD.

20 BESSEMER STREET, BLACKTOWN NSW 2148 AUSTRALIA
TEL: (61 2) 9672 - 3222 FAX: (61 2) 9672 - 8733
E - MAIL: sales@kpm.com.au WEBSITE: www.kpm.com.au

Bulk Bag

Loading & Unloading Systems

Klausen Process Machinery Pty Ltd is proud to introduce the Bulk Bag Loading and Unloading Systems. These systems are designed to easily load or unload Bulk and Semi Bulk Bags.

The most important aspect of such a system is its ability to isolate and sustain a dust free environment while being efficient and economical.

For unloading, the system works by placing the Bags containing the material in a Bulk Bag Unloading Frame by a forklift, or by monorail hoist. For difficult products, an agitating system is used in the lower half of the bag to knead the product and promote material flow from the bag. Materials can be discharged into a Duraflex Feeder for direct metering to your process.

The loading system works in the opposite manner of the unloading system however under the same principle.

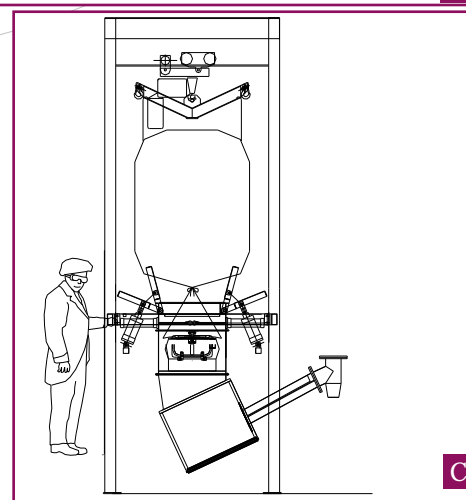
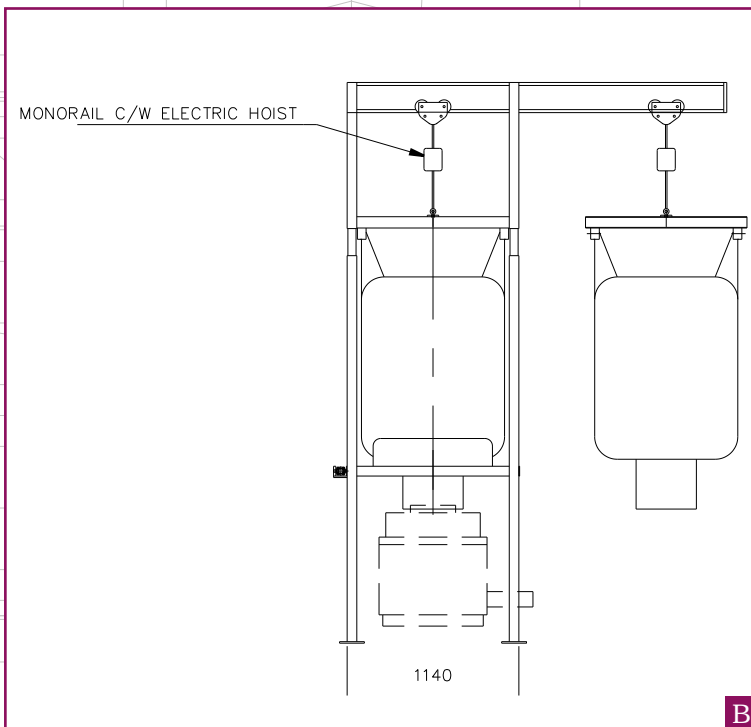
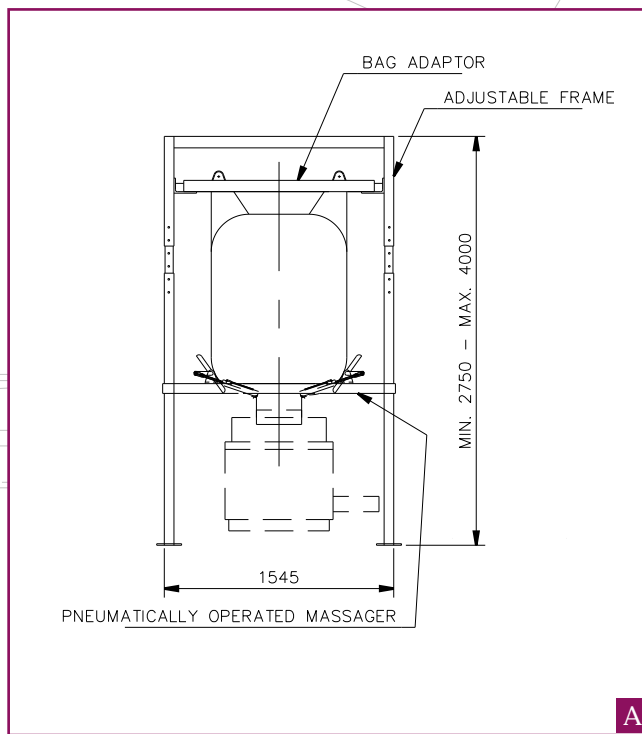

KLAUSEN PROCESS MACHINERY PTY. LTD.

20 BESSEMER STREET, BLACKTOWN NSW 2148 AUSTRALIA
TEL: (61 2) 9672 - 3222 FAX: (61 2) 9672 - 8733
E - MAIL: sales@kpm.com.au WEBSITE: www.kpm.com.au