

# Global Autofry<sup>3</sup> Donut Machine

Model: OBCDM5

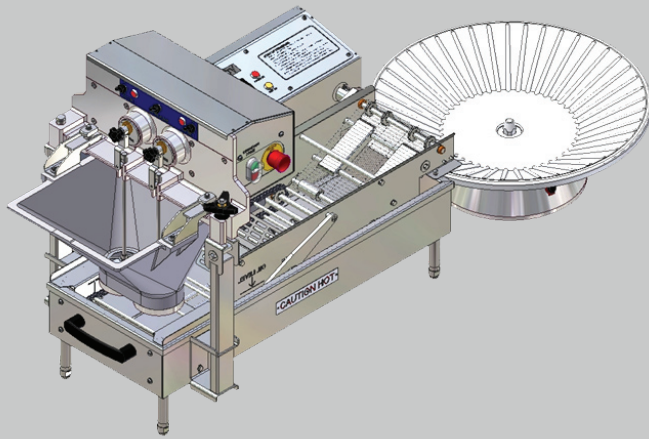

## OVERALL DIMENSIONS

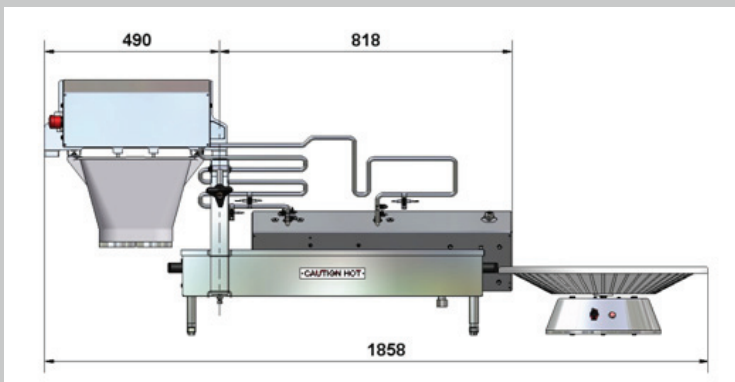
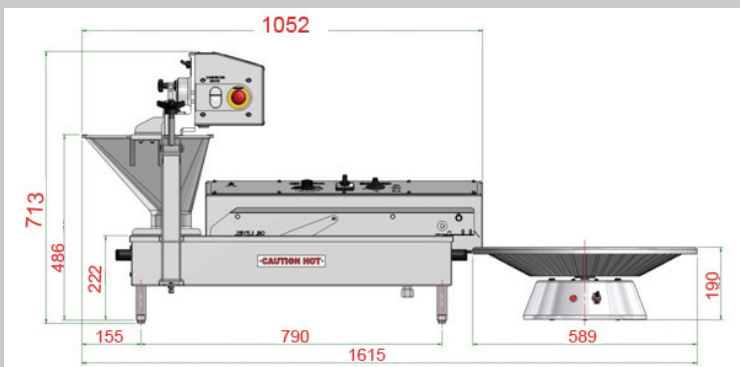

## MAIN TECHNICAL FEATURES

**Electrical:** 208V, 60HZ, 20.2A with 3 metre (9.84 feet) cable

**Electrical:** 240V, 50HZ, 25.6A with 3 metre (9.84 feet) cable

**Thermostat:** Robertshaw

**Heater Pilot:** Red neon

**Hopper Capacity:** 7,5kgs (16.5 pounds) donut mix

**Fryer Tank Capacity:** 13 to 16kgs (29 to 35 pounds) of shortening

**Fryer Tank Volume:** 21 litres (5.55 gallons)

**Production Capacity:**

456pcs (38 dozens) per hour of 50gms (1.9 ounces) donut cake

912pcs (76 dozens) per hour of 20gms (0.7 ounces) donut cake

## CONSTRUCTION

- Tank, frame, legs, control panel 304 stainless steel
- Hopper & cutter head cast aluminium
- Gear drive mechanism with chain drive conveyor

## WEIGHT

- Appliance: 75kg (165.4 pounds).
- Appliance with packaging & accessories: 180kg (396.8 pounds)

## OPTIONS

- Hopper Divider
- Mini Donut Hopper & Plungers
- Stainless Steel Bench
- Stainless Steel Bench with Exhaust Hood
- Oil Drain Kit

