

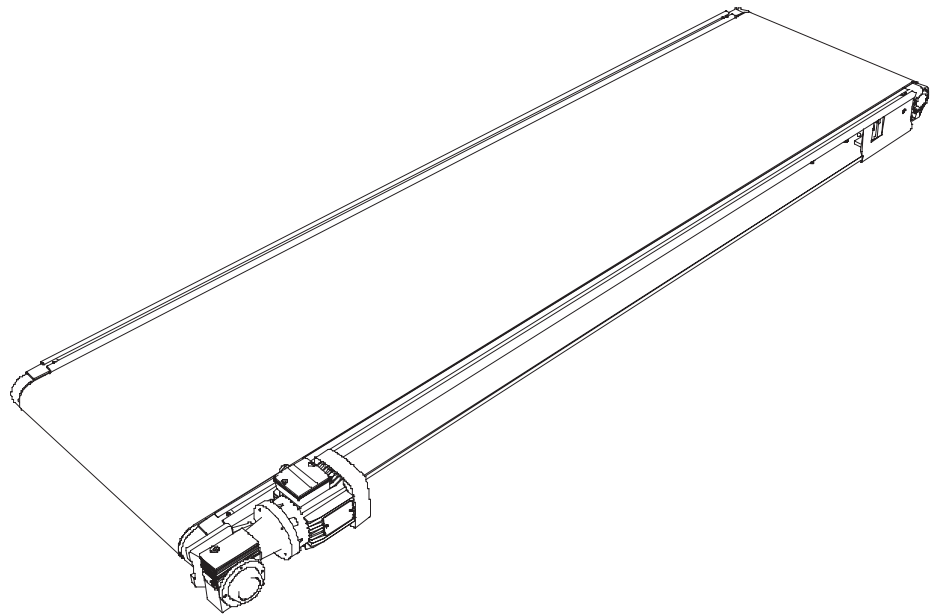

WE MAKE THE WORLD MOVE



Operating Instructions
INTERROLL Belt Conveyor
Type 4081

Manufacturer's address

Interroll Automation GmbH
Untere Au 4
74889 Sinsheim, Germany
Phone: +49 7261 938 – 0
Fax: +49 7261 938 – 124
www.interroll.com
automation@interroll.com

Copyright

The copyright for these operating instructions remains with **Interroll Automation GmbH**. The operating instructions contain technical regulations and drawings which may not be reproduced partially or in full, transmitted by any means, utilized without permission for competitive purposes or disclosed to third parties.

Table of contents

About this document

| | |
|--|---|
| Information about the operating instructions | 3 |
| Warning signs in this document | 4 |
| Other symbols | 4 |

Safety

| | |
|---------------------------------------|---|
| Basic safety instructions | 5 |
| Intended use | 5 |
| Incorrect use | 5 |
| Specialists | 5 |
| Electricians | 5 |
| Dangers | 6 |
| Interfaces to other devices | 6 |
| Operating modes | 7 |

Product identification

| | |
|---|----|
| Components | 8 |
| Characteristic | 11 |
| Product variants | 12 |
| Type plate | 13 |
| Identifying the conveyor type | 14 |
| Entering the type designation | 14 |

Transport and storage

| | |
|---------------------|----|
| Transport | 16 |
| Storage | 16 |

Assembly and installation

| | |
|-----------------------------------|----|
| Assembly | 17 |
| Electrical installation | 17 |

Start-up and operation

| | |
|---|----|
| Initial start-up | 18 |
| Operation | 19 |
| Procedure for accidents or malfunctioning | 19 |

Cleaning, maintenance and repairs

| | |
|---|----|
| Cleaning | 20 |
| Maintenance and repair work information | 20 |
| Adjusting tension and straight running of the belt for head drive, over drive and belt drive | 21 |
| Adjusting tension and straight running of the belt for centre drive | 22 |
| Replacing the belt with head and belt drive | 23 |
| Replacing the belt with over drive | 24 |
| Replacing the belt with centre drive | 25 |
| Replacing the over drive roller with over drive | 26 |
| Replacing the drive/end roller with head drive, Replacing the end roller with centre drive and belt drive | 27 |
| Maintenance intervals | 28 |
| Maintenance and inspection list | 28 |

Troubleshooting

| | |
|-------------------------------------|----|
| In case of malfunctioning | 29 |
| Troubleshooting | 29 |



Table of contents

Spare and wear parts

| | |
|---|----|
| Spare parts drawing for head drive type 4081.1 | 30 |
| Spare parts drawing for incline/decline conveyor type 4081.3 | 31 |
| Spare parts drawing for angled conveyor type 4081.4 | 32 |
| Spare parts drawing for angled conveyor with power feeder/outfeeder belt type 4081.6 | 33 |
| Spare parts drawing for incline/decline conveyor with power feeder/outfeeder belt type 4081.8 | 34 |
| Spare parts list types 4081.1, 4081.3, 4081.4, 4081.6 and 4081.8 | 35 |
| Spare parts drawing for centre drive type 4081.2 | 36 |
| Spare parts list for type 4081.2 | 37 |
| Spare parts drawing for over drive type 4081.7 | 38 |
| Spare parts list for type 4081.7 | 39 |
| Order details | 40 |

Shut-down and disposal

| | |
|-------------------------------------|----|
| Shut-down and disposal | 41 |
| Environmental regulations | 41 |

Manufacturer's declaration

About this document

Information about the operating instructions

Contents

These operating instructions contain important details and information about the various operating phases of the conveyor:

- Transport, assembly and start-up
- Safe operation, required maintenance, remedy of possible faults
- Spare parts, supplementary accessories

Product affiliation

The operating instructions describe the finished conveyor at the time of initial delivery.

Supplementary to these operating instructions, special contractual agreements and technical documents apply for special conveyor versions and additional appliances.

These operating instructions are an integral part of the conveyor

- To ensure trouble-free and safe operation as well as the settlement of any warranty claims, always read these operating instructions first and observe all the information contained herein.
- Keep these operating instructions close to the conveyor.
- Always give the operating instructions to each subsequent owner or user. Interroll shall not accept liability for any damages or malfunctioning caused by non-adherence to these operating instructions.
- Please contact Interroll Customer Service if you have any further questions after reading these operating instructions. See the last page for your local contact.

About this document

Warning signs in this document

The warning signs in this document provide information about dangers which may arise during conveyor operation. The relevant warning signs are displayed in the "safety" section, see "Safety", page 5 and at the beginning of each chapter.

There are three types of warning signs:

- DANGER
- WARNING
- CAUTION

| Signal word | Meaning | Consequences of non-adherence |
|-------------|---|---|
| DANGER | warns of an imminent danger | death or serious injuries. |
| WARNING | warns of a possible danger | death or serious injuries are possible. |
| CAUTION | warns of a possibly dangerous situation | slight injuries are possible. |

Warning sign design



DANGER

The type and source of the imminent danger is specified here!
Possible consequences of non-adherence are stated here.

- Protective measures against the danger are listed here.

- Always read and carefully observe all warning signs.

Other symbols

NOTICE

This sign specifies possible property damages.
➤ Protective measures against property damages are listed here.



This symbol displays safety instructions.



This symbol displays useful and important information.

- This symbol refers to an actual task.

Safety

Basic safety instructions

The conveyor was state of the art and generally safe to operate at the time of delivery; however dangers may still arise during utilization:

- Danger of death or personal injury to operators and others
- Adverse effects on the conveyor and other areas



Non-adherence to the information in these operating instructions can result in life-threatening injuries!

- Read these operating instructions carefully and adhere to the information contained herein to ensure safe conveyor operation.

Intended use

The conveyor is intended for use in industrial environments and should only be applied to transport goods, such as parts, boxes or crates.

Application area

The conveyor is intended for certain application areas only (see "*Product identification*", page 8 and the following) and its defined capacity limits must not be exceeded during operation.

Any other use is not permitted. Operating conditions which deviate from those specified require new contractual agreements.

Conveyor modifications

Users are not permitted to carry out alterations or modifications which will have an adverse effect on safety.

Incorrect use

The conveyor is not intended for transporting people and small parts.

Bulk goods should not be transported; possible exceptions require new contractual agreements.

Specialists

Specialists are personnel who have the knowledge to read and understand the operating instructions and the ability to carry out work professionally while observing national regulations.

Electricians

According to German accident prevention regulations (BGV A2), electricians must be able to assess and recognize possible dangers when performing entrusted tasks due to their professional training, know-how, experience and knowledge of relevant regulations.

Safety

Dangers



This section provides information about various dangers and damages which may occur when operating the conveyor.

Safety equipment

- Only carry out maintenance and repair work once the machine has been de-energised and measures have been taken to ensure that it cannot be started accidentally.
- Organise additional safety measures for passageways and to stop people reaching into the moving conveyor.
- Never remove protective covers or housings.
- Regularly inspect safety equipment.

Electricity

- Never reach into a live machine.

Rotating parts

- Never wear loose clothing.
- Never wear jewellery, such as necklaces or bracelets.
- If you have long hair, always wear a hair net.

Falling objects/Work environment

- Always remove materials and objects which are not required from the work area.
- Wear safety shoes.
- Regulate and monitor the position of goods.

Malfunctioning during operation

- Regularly inspect the conveyor for visible damage.
- Stop the device immediately and ensure that it cannot be started accidentally in the event of:
Smoke, unusual noises, trapped or broken goods, defective support stands, side guides or accessory appliances.
- A specialist must locate the source of the fault immediately.
- Immediately clean up any leaked gear oil.
- Do not climb on the conveyor during operation.

Maintenance intervals

- Carry out maintenance and inspections regularly.
- Only use original spare parts.

Interfaces to other devices

Danger zones can arise when integrating the conveyor into a system. These zones will not be described in these operating instructions and must be analyzed during installation and initial start-up of the respective system.

- After connecting the conveyor to other conveyors or machines, always check for new danger zones prior to initial start-up. Especially at the end roller shaft where cuts and crushing can occur.
- If necessary, implement further constructional measures.



A transition profile can be fitted to eliminate danger zones.

Safety

Operating modes

| | |
|---------------------|--|
| Normal mode | Operation when installed at the end customer's as an individual conveyor or as a conveyor in a system. |
| Special mode | All operating modes which are required to guarantee and maintain safe and normal operation. |

| Special operating mode | Explanation | Comment |
|----------------------------------|--|-------------------|
| Transport/Storage | Loading and unloading, transport and correct storage | - |
| Assembly/Initial start-up | Installation at the end customer's and execution of a test run | - |
| Cleaning | Cleaning the outside without removing safety equipment | When de-energized |
| Maintenance/Repairs | Maintenance and inspection tasks | When de-energized |
| Troubleshooting | Troubleshooting during normal operation | - |
| Fault elimination | Eliminating the fault | When de-energized |
| Shut-down | Removal from the system | When de-energized |
| Disposal | Removal from the system and disassembly | When de-energized |

Product identification

Components

4081.1

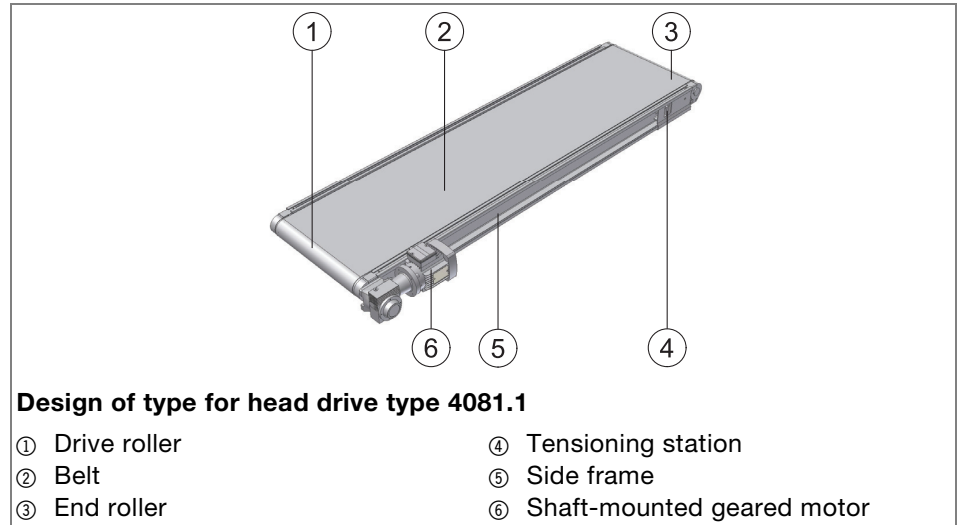

4081.2

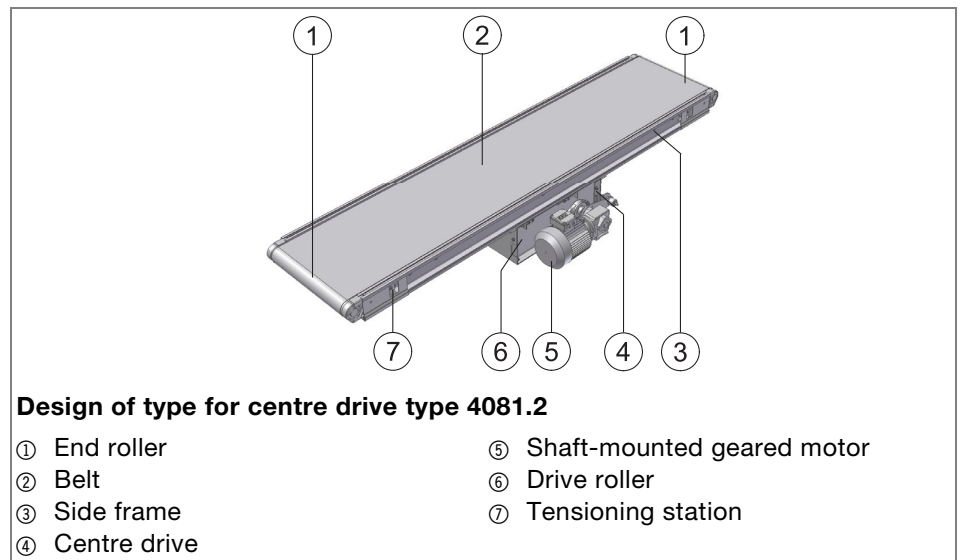

Product identification

4081.3

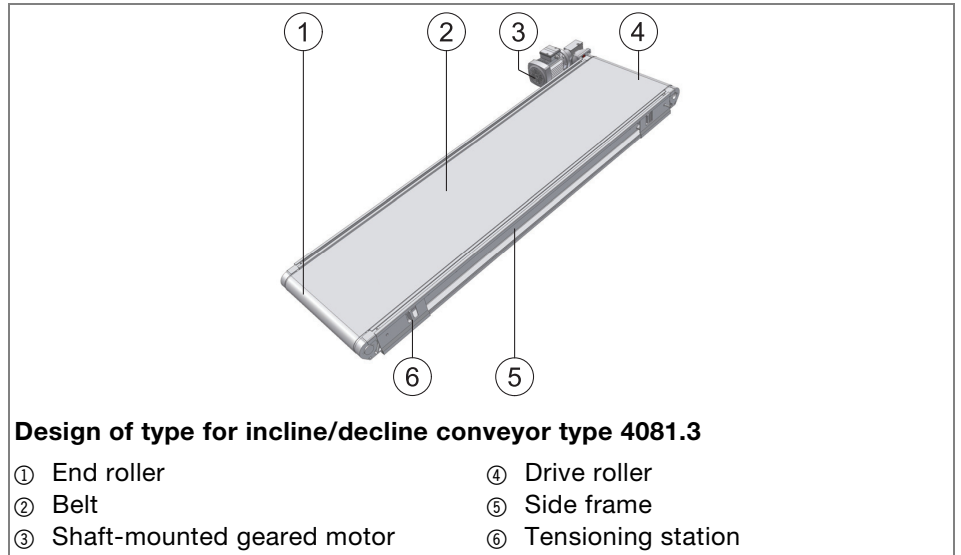

4081.4

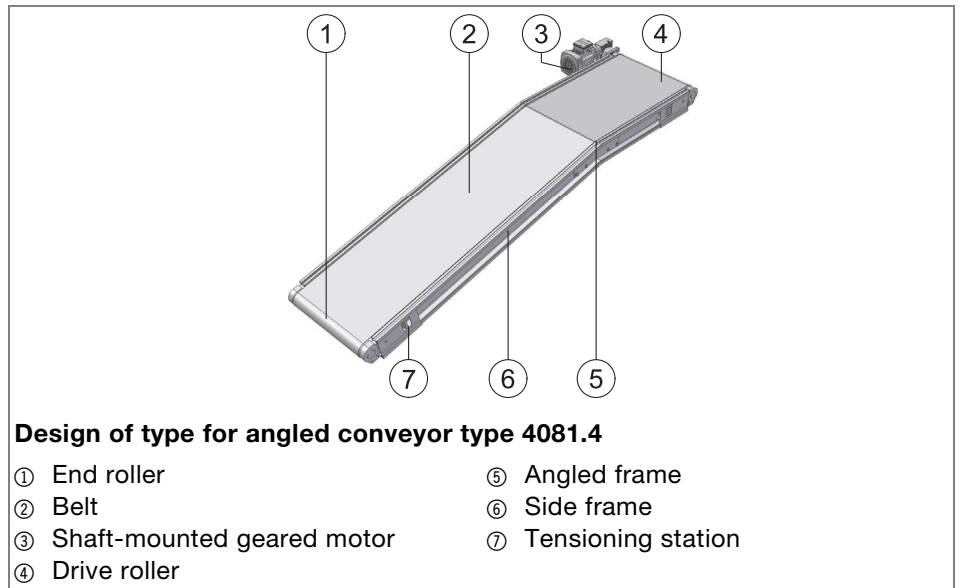

Product identification

4081.6

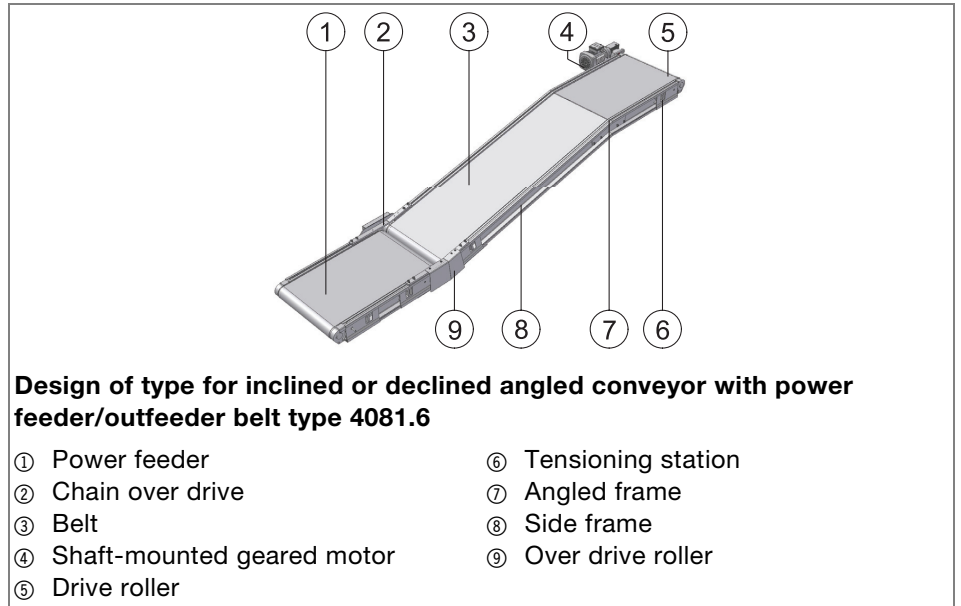

4081.7

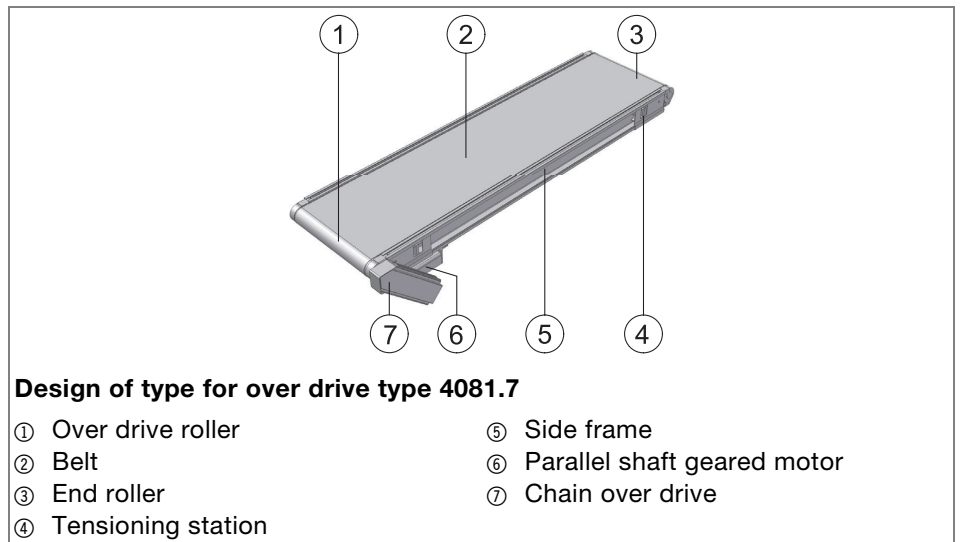

Product identification

4081.8

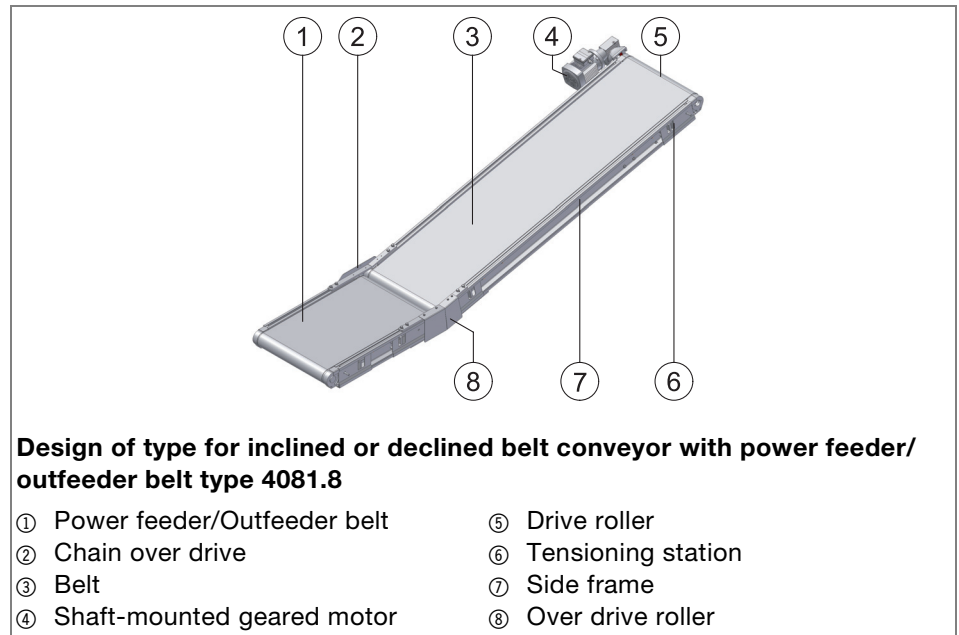

Characteristic

Conveyor belt type 4081 is designed to transport goods, boxes, containers, cardboard boxes, etc., especially over long distances. A special version also allows the transportation of certain bulk goods.

The conveyor belt is available in numerous sizes, variants and special versions, e. g. :

- with over drive, head or centre drive, belt drive
- as a horizontal conveyor up to 50 m long
- as an incline/decline conveyor
- as an angled conveyor with power feeder or outfeeder belt

Product identification

Product variants

| Type 4081 | Technical data*, ** |
|---|---|
| Load area | <ul style="list-style-type: none"> • Head drive: max. 300 N/m (30 kg/m) • Centre drive: max. 500 N/m (50 kg/m) • Over drive/Belt drive: max. 250 N/m (25 kg/m) |
| Conveying speed | 0.05 m/s to 6 m/s |
| Lane widths (LW) | 310 mm up to 2,500 mm (in increments of 50 mm) |
| Conveyor length (CL) | 1,000 mm to 30,000 mm |
| Horizontal length top (TL) | 5,000 mm (with fixed angled frame) |
| Power feeder/Outfeeder belt (BL/ TL) | 800 mm to 5,000 mm |
| Drive | <ul style="list-style-type: none"> • For head drive: 3-phase shaft-mounted geared motor; 400 V / 230 V; 50 Hz • For belt drive: 3-phase; 400 V / 230 V; 50 Hz • For centre drive: 3-phase shaft-mounted geared motor; 400 V / 230 V; 50 Hz • For chain over drive with parallel shaft geared motor: 3-phase; 400 V / 230 V; 50 Hz |
| Conveyor belt | 2-layer polyester belt with PVC or PU cover |
| Incline/Decline | Max. 15° |
| Belt return | Plastic-coated wooden base plate / Galvanised steel base plate |
| Shafts | <ul style="list-style-type: none"> • Drive roller: Ø80 mm; Ø92 mm; Ø120 mm; Ø132 mm • End roller: Ø20 mm; Ø40 mm; Ø80 mm; Ø92 mm; Ø120 mm |
| Storage | Maintenance-free spherical bearing and flange bearing |
| Frame | Extruded, anodised aluminium profile |
| Conveyor weight | From 50 kg to 1,000 kg |
| High side guide | 20 mm to 800 mm |
| Temperature range | -5 °C to +50 °C ambient temperature |
| Humidity | Max. 90%, non-condensating |
| Ambient conditions | Not suitable for application in areas with chemically aggressive media, e.g. acids or alkalis. Exceptions only after prior consultation. |
| Noise | Leq < 70 dB(A) |
| Accessories | <ul style="list-style-type: none"> • Protective motor switch incl. 5 m cable and CEE plug • Digital stop and run timer, adjustable pulse and interval time, incl. on/off switch for continuous operation and a protective motor switch • Frequency converter • Light barrier and reflector • Clear sensor / switch |

* depending on the variant, ** special versions possible

Product identification

Type plate

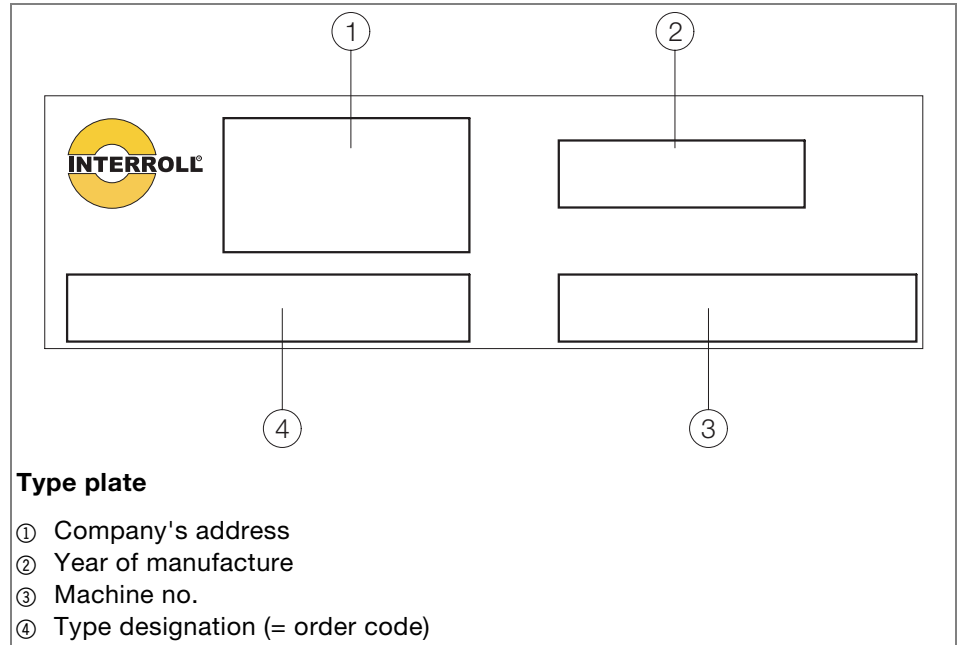

The type plate specifications identify the conveyor. The type designation is required for correct application of the conveyor.



The type plate is located close to the geared motor.

Product identification

Identifying the conveyor type

Type designation details

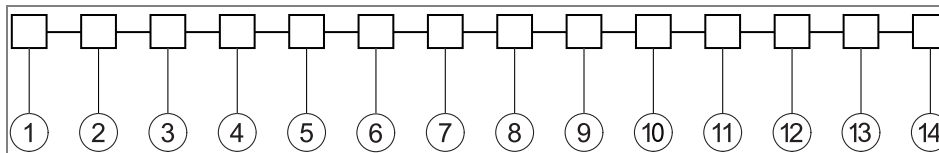

Type designation

Entering the type designation

➤ Determine the type designation details and enter them here as reference.

| Pos. | Characteristic | Type plate details | Unit/Comment |
|------|----------------------------|--------------------|---|
| ① | Type no. | | 4081.1 = Head drive 4081.2 = Centre drive 4081.3 = Incline/Decline conveyor 4081.4 = Angled conveyor 4081.6 = Angled conveyor with power feeder/outfeeder belt 4081.7 = Over drive 4081.8 = Incline/Decline conveyor with power feeder/outfeeder belt |
| ② | Lane width (LW) | | mm |
| ③ | Conveyor length (CL) | | mm |
| ④ | Bottom length (BL) | | mm |
| ⑤ | Top length (TL) | | mm |
| ⑥ | High side guide | | mm 0 = Without side guide |
| ⑦ | Loading height (T.O.B.1) | | mm |
| ⑧ | Unloading height (T.O.B.2) | | mm |
| ⑨ | Direction of travel | | IN = inclined DE = declined |
| ⑩ | Belt type | | BF = Black SF = Special version |
| ⑪ | Conveying speed (V) | | m/s |
| ⑫ | Drive end | | LH = Left-hand mounted RH = Right-hand mounted BD = Belt drive |
| ⑬ | Applied load | | kg/m |
| ⑭ | Special | | S = Special version |

Product identification

Type designation example

Type designation 4081.6-610-3000-5000-5000-80-600-1500-IN-BF-0.5-LH-30

- Conveyor belt with inclined angled conveyor and power feeder/outfeeder belt type 4081.6
- Lane width = 610 mm
- Conveyor length = 3,000 mm
- Bottom length = 5,000 mm
- Top length = 5,000 mm
- Side guide = 80 mm
- Loading height = 600 mm
- Unloading height = 1,500 mm
- Direction of travel = Inclined
- Belt type = Black
- Conveying speed = 0.5 m/s
- Drive end = Left-hand mounted
- Applied load = 30 kg/m
- No special version

Transport and storage

Transport

| | |
|---|----------------|
|  | CAUTION |
| <p>Risk of injuries due to incorrect transport!</p> <ul style="list-style-type: none"> ➤ Transport must be carried out by qualified and authorized personnel. | |



Refer to the enclosed data sheet for information about conveyor transport.

- Refer to the enclosed data sheet for details about the weight and requirements for load carrying and load securing equipment.
- Ensure people are not in the danger zones.
- Wear safety shoes.
- Check secure fastening for transport

The lifting points are marked on the conveyor.

Lifting point identification



After delivery

- Inspect the delivery for transport damages. Notify the transport company and the manufacturer immediately if any defects are detected to prevent claims being refused.

Storage

| | |
|---|----------------|
|  | WARNING |
| <p>Risk of injuries due to incorrect storage!</p> <ul style="list-style-type: none"> ➤ Do not stack conveyors on top of each other. Do not place other objects on the conveyor. ➤ Check the stability of the conveyor. | |

- If the conveyor is not to be used immediately, store and protect it from moisture and dust.

Assembly and installation

Assembly

The conveyor is supplied fully pre-assembled at the installation site and only has to be erected and connected.

- Set the conveyor to the desired height via the adjustable feet and use the counternuts to fix them.
Use a spirit level and a level for this task.
- Secure the conveyor, ensuring it is not twisted or warped.
- When aligning the module, make sure there is no contact between moving parts.



WARNING

Risk of injuries due to incorrect assembly!

- Assembly must be carried out by qualified personnel in accordance with the safety instructions.
- Carefully assemble all the connections, e.g. cables, hoses and pipes, and check that they are connected correctly.



Pay attention to the tracking profile attached to the belt, it should not rub against the conveyor! During alignment, ensure that a minimum distance of 5 mm is observed for all operating conditions.

- After conveyor installation, make sure passageways are clear of obstacles. If necessary, assemble walkways.
- When integrating the conveyor in a system, always consider possible danger zones, especially where cuts and crushing can occur.

Electrical installation



DANGER

Danger of death due to live cable ends!



- Electrical installation should only be carried out by qualified electricians.
- Disconnect from the power supply.
- Observe the minimum bend radii of the cables, hoses and wires.

Power is supplied to the conveyor either via a CEE plug or direct installation in a control panel.

- Always check cables and assemblies for damages prior to installation.
- Refer to the motor's type plate for connection values.
- Connect the motor in accordance with EN-IEC 60204-1. Refer to the motor's terminal box for wiring information.

Start-up and operation

Initial start-up

| | |
|---|--|
|  |  WARNING |
| <p>Risk of injuries due to incorrect handling!</p> <ul style="list-style-type: none"> ➤ Check electrical connections and protective equipment. ➤ Remove conveyed material from the conveyor. ➤ Ensure unauthorized persons are not in the danger zones. ➤ Wear safety shoes and suitable work clothes. | |

The conveyor has been factory tested. The belt adjustment or the belt tension is factory set and does not usually have to be altered.

Nevertheless, the following check must be carried out:

- Check the direction of travel prior to initial start-up. If necessary, correct the direction.

The conveying direction is indicated by an arrow at the conveyor.

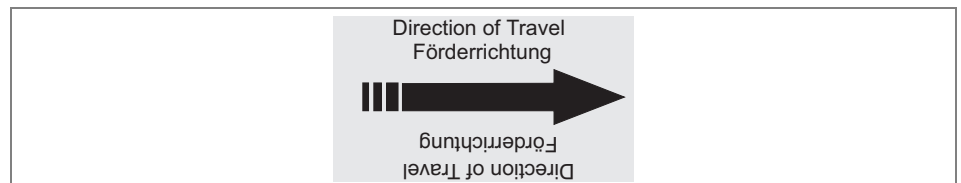

- If faults occur during initial start-up, adjust the belt setting.

Start-up and operation

Operation

Prior to each operation

- Check the conveyor for visible damage. Pay special attention to belt, guides and support stands.
- Ensure that all safety equipment is functioning correctly.
- Make sure that only authorised persons are in the conveyor's work area.
- Always remove materials and objects which are not required from the work area.
- Provide instructions about and monitor correct loading of the conveyor.

During operation

| | |
|---|----------------|
|  | WARNING |
| <p>Rotating parts! Crushing and serious injuries due to being caught and pulled into the conveyor!</p> <ul style="list-style-type: none">➤ Do NOT remove the protective covers.➤ Never wear loose work clothes, jewellery or chains.➤ If you have long hair, always wear a hair net. | |

- If goods become trapped in the side guides, switch off the conveyor and ensure that it cannot be started accidentally, then eliminate the fault.

Procedure for accidents or malfunctioning

- Stop the device and ensure that it cannot be started accidentally.
- In case of an accident: If necessary, apply first aid treatment and make an emergency call.
- Inform a specialist.
- A specialist must eliminate the fault.
- Only restart the device after it has been deemed safe and released by a specialist.

Cleaning, maintenance and repairs

Cleaning



WARNING

Risk of injuries due to incorrect handling!

- Ensure the conveyor is de-energized before cleaning it. Disconnect the power supply and ensure that it cannot be connected accidentally.
- Do not remove safety equipment.
- Wear safety shoes and close fitting work clothes.

- Only dry clean the belts.
- Only use suitable cleaning agents.
- Clean panels on the underside with compressed air.

Maintenance and repair work information



DANGER

Danger of death due to high voltages!

- Switch off the supply network system, ensuring that the device cannot be started accidentally and that the power supply has been disconnected correctly.

- Work at electrical appliances should only be carried out by authorized and qualified electricians.
- Display signs warning of maintenance and repair work when carrying out tasks.
- Cordon off the area around the conveyor.
- Inform people entering the cordoned off area of the risks.

Cleaning, maintenance and repairs

Adjusting tension and straight running of the belt for head drive, over drive and belt drive

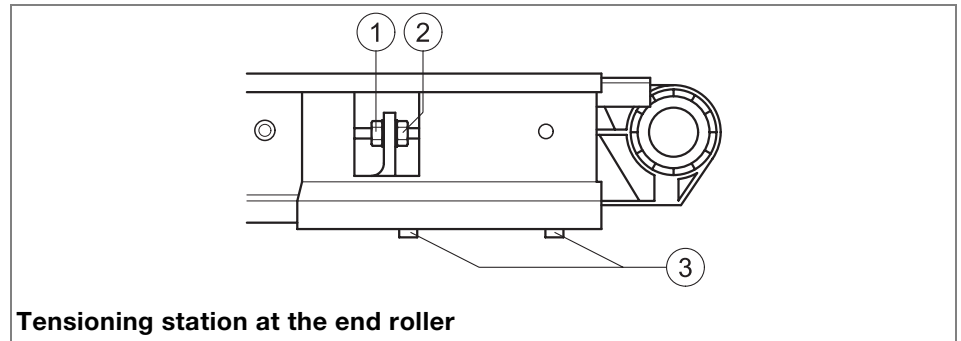

Never loosen the fastening screws ③ at the tensioning console!

Adjusting the belt tension

The required adjustments are carried out at the tensioning stations of the end roller (opposite the drive roller).



Tension the belt so that conveyed goods are transported safely at full load (load expansion of the belt < 0.1 %)!

- Loosen the nut ① at both tensioning stations of the end rollers.
- Turn the nut ② to tension or release the belt.
- Lock the nut ① to fix the tensioning station.

Adjusting straight running of the belt

Straight running is adjusted at the tensioning station of the deflection side and at the drive end (opposite the geared motor, head and chain drive).

However, it is enough to adjust the belt tension at just one tensioning station.



Do not carry out adjustments at the geared motor end!

- Adjust the belt tension at one tensioning station as described above. (Example: The running side must be slackened.)
Make sure that the belt is positioned in the middle between the side frames.
- Carry out a test run with at least four complete belt turns.

Cleaning, maintenance and repairs

Adjusting tension and straight running of the belt for centre drive

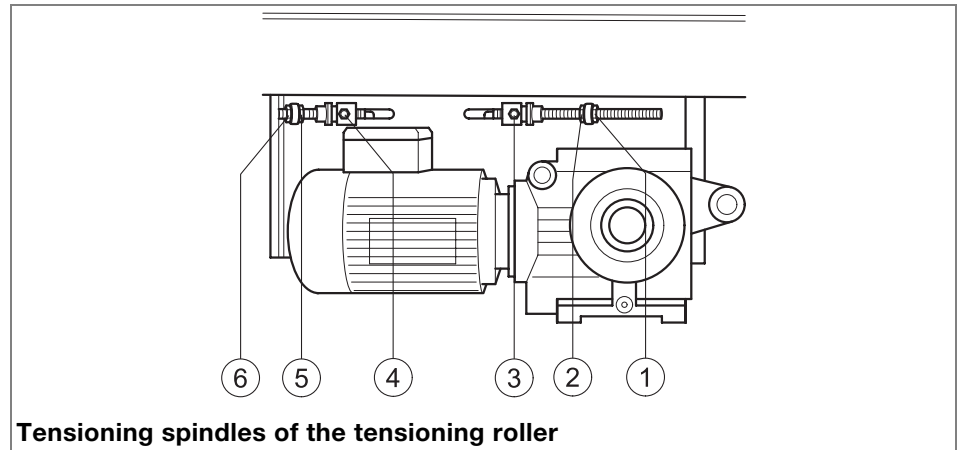

Adjusting the belt tension

The required adjustments are carried out at the centre drive console.



Tension the belt so that conveyed goods are transported safely at full load (load expansion of the belt < 0.1 %)!

- Loosen the clamping screw ③ at the tensioning roller.
- Loosen the nut ① at the tensioning spindle of the tensioning roller.
- Turn the nut ② to tension or release the belt.
- Tighten the nut ① and the clamping screw ③ to fasten the tensioning roller.

Adjusting straight running of the belt

- Loosen the clamping screw ④ of the straight running roller.
- Use the nuts ⑤ and ⑥ to adjust straight running.
Make sure that the belt is positioned in the middle between the centre drive console (or the side frames).
The running side must be slackened.
- Carry out a test run with at least four complete belt turns.

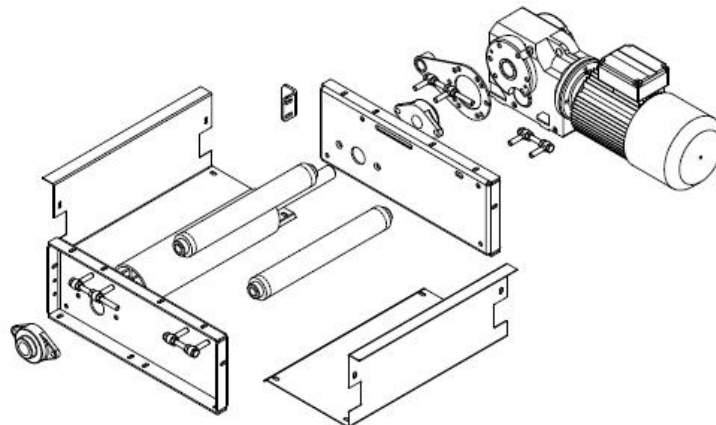

Cleaning, maintenance and repairs

Replacing the belt with head and belt drive

Required equipment:

- Crane or trestles
- Wedges or blocks for jacking or jamming

Disassembling the belt

- Disconnect the belt conveyor from the power supply.
- Release the drive and end roller tension.
- Raise the belt conveyor and use a crane or trestles to support it.
- Remove the support stands and side guides.
- If applicable, remove idling rollers from the underside, including respective retaining plates and guards.
- Move belt conveyor 90° to the side and position carefully.
- Pull the belt off the side frame from the side.

Installing the belt

- Assemble and tension a new belt.
- Re-assemble the belt conveyor in reverse order.
- Adjusting tension and straight running of the belt, see "*Adjusting tension and straight running of the belt for head drive, over drive and belt drive*", page 21.
- Carry out a test run with at least four complete belt turns.

Cleaning, maintenance and repairs

Replacing the belt with over drive

Required equipment:

- Crane or trestles
- Wedges or blocks for jacking or jamming

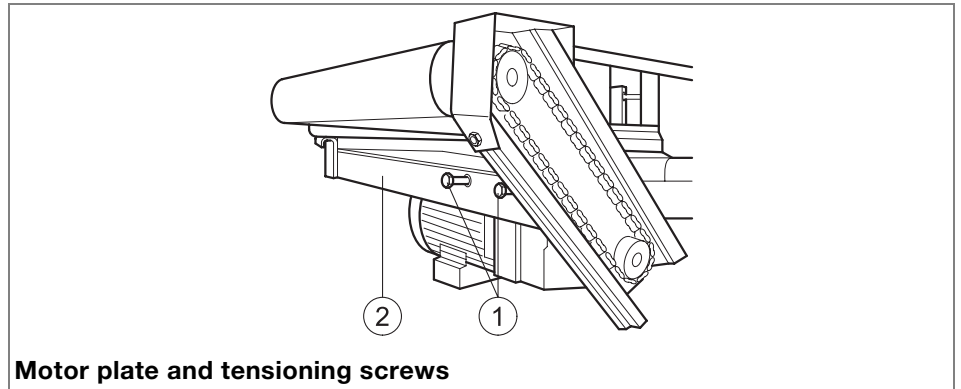

Disassembling the belt

- Disconnect the belt conveyor from the power supply.
- Disassemble the chain guard.
- Release the over drive and end roller tension.
- Loosen the tensioning screws ① and fastening screws of the parallel shaft geared motor at the motor plate ②.
- Move the geared motor towards the over drive roller.
- Disassemble the chain and sprocket from the parallel shaft geared motor.
- Disassemble the motor plate with parallel shaft geared motor.
- Raise the belt conveyor and use a crane or trestles to support it.
- Remove the support stands and side guides.
- If applicable, remove idling rollers from the underside, including respective retaining plates and guards.
- Move belt conveyor 90° to the side and position carefully.
- Pull the belt off the side frame from the side.

Installing the belt

- Assemble and tension a new belt.
- Re-assemble the belt conveyor in reverse order.
- Adjusting tension and straight running of the belt, see "*Adjusting tension and straight running of the belt for head drive, over drive and belt drive*", page 21.
- Carry out a test run with at least four complete belt turns.

Cleaning, maintenance and repairs

Replacing the belt with centre drive

Required equipment:

- Crane or trestles
- Wedges or blocks for jacking or jamming

Disassembling the belt

- Disconnect the belt conveyor from the power supply.
- Remove the cover plates from the centre drive console.
- Loosen the eye bolts on both sides of the centre drive console and disassemble the straight running roller and the tensioning roller.
- Raise the belt conveyor and use a crane or trestles to support it.
- Remove the support stands and side guides.
- If applicable, remove idling rollers from the underside, including respective retaining plates and guards.
- Move belt conveyor 90° to the side and position carefully.
- Pull the belt off the side frame from the side.

Installing the belt

- Assemble and tension a new belt.
- Re-assemble the belt conveyor in reverse order.
- Adjusting tension and straight running of the belt, see "*Adjusting tension and straight running of the belt for centre drive*", page 22.
- Carry out a test run with at least four complete belt turns.

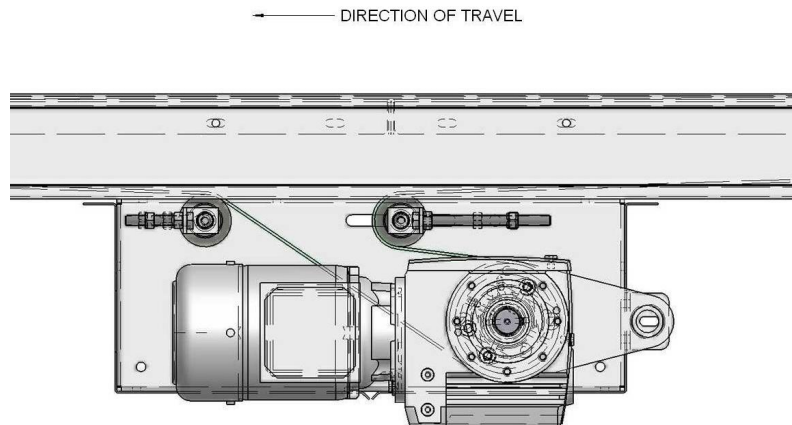

Cleaning, maintenance and repairs

Replacing the over drive roller with over drive

Required equipment:

- Crane or trestles
- Wedges or blocks for jacking or jamming

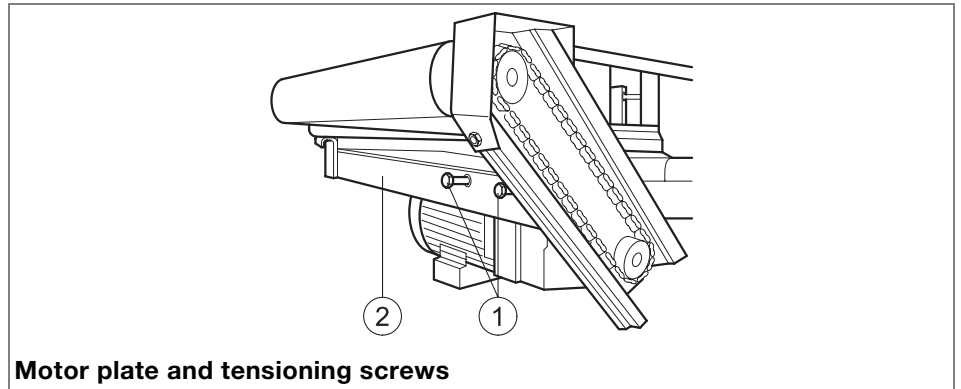

Disassembling the roller

- Disconnect the belt conveyor from the power supply.
- Disassemble the chain guard.
- Release the over drive and end roller tension.
- Loosen the tensioning screws ① and fastening screws of the parallel shaft geared motor at the motor plate ②.
- Move the geared motor towards the over drive roller.
- Disassemble the chain and sprocket from the parallel shaft geared motor.
- Disassemble the motor plate with parallel shaft geared motor.
- Raise the belt conveyor and use a crane or trestles to support it.
- Remove the support stands and side guides.
- If applicable, remove idling rollers from the underside, including respective retaining plates and guards.
- Move belt conveyor 90° to the side and position carefully.
- Pull the belt off the side frame from the side.
- Unscrew and remove the nut ① of the tensioning station.
- Extract the roller including the tensioning station from the tensioning console.

Assembling the roller

- Assemble a new roller including a new spherical bearing in reverse order.
- Re-assemble the belt conveyor in reverse order.
- Adjusting tension and straight running of the belt, see "*Adjusting tension and straight running of the belt for head drive, over drive and belt drive*", page 21.
- Carry out a test run with at least four complete belt turns.

Cleaning, maintenance and repairs

Replacing the drive/end roller with head drive, Replacing the end roller with centre drive and belt drive

Required equipment:

- Crane or trestles
- Wedges or blocks for jacking or jamming

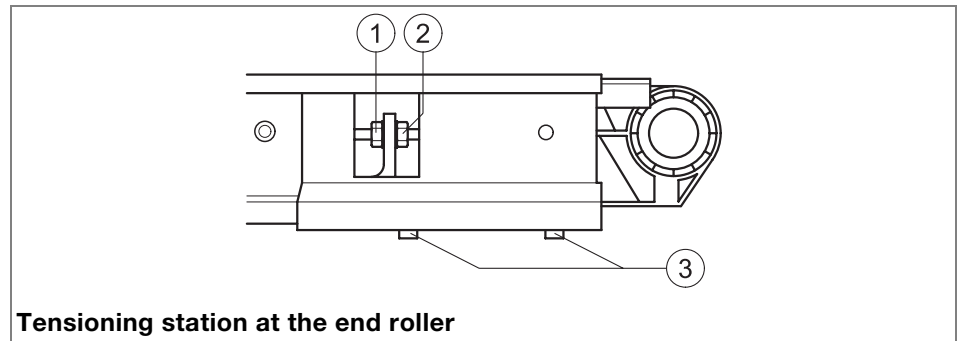

Disassembling the roller

- Disconnect the belt conveyor from the power supply.
- Remove the geared motor when replacing the drive roller.
- Release the drive and end roller tension.
- Raise the belt conveyor and use a crane or trestles to support it.
- Remove the support stands and side guides.
- If applicable, remove idling rollers from the underside, including respective retaining plates and guards.
- Move belt conveyor 90° to the side and position carefully.
- Pull the belt off the side frame from the side.
- Unscrew and remove the nut ① of the tensioning station.
- Extract the roller including the tensioning station from the tensioning console.

Assembling the roller

- Assemble a new roller including a new spherical bearing in reverse order.
- Re-assemble the belt conveyor in reverse order.
- Adjusting tension and straight running of the belt, see "*Adjusting tension and straight running of the belt for head drive, over drive and belt drive*", page 21 or see "*Adjusting tension and straight running of the belt for centre drive*", page 22.
- Carry out a test run with at least four complete belt turns.

Cleaning, maintenance and repairs

Maintenance intervals

Refer to the manufacturer's documentation for information about lubricating intervals and maintenance tasks at the motor.



All the conveyor's bearings have lifetime lubrication and are maintenance free at operating temperatures of between -5 °C and +50 °C in a low dust and low moisture environment.

Maintenance and inspection list

| Mach. no./Type: | Date: | | | |
|-----------------------------|-----------------|---|-------------------------|-----------------------|
| Part | Interval | Task/Inspection | Required work | Carried out by |
| Entire conveyor | Weekly | General visual inspection | | |
| | Monthly | Check screwed connections | Re-tighten if necessary | |
| Drive rollers/End rollers | Monthly | Listen for noise development | Replace, if necessary | |
| | | Check for damage | | |
| Belt | Monthly | Check operating behaviour and voltage | Adjust, if necessary | |
| | | Check for damage | Replace, if necessary | |
| | | Check belt support end for soiling | Clean, if necessary | |
| Bearings | Quarterly | Check for operating noise | Replace, if necessary | |
| Geared motor | Quarterly | Check drive (visual inspection) | | |
| | | Check temperature | | |
| | | Listen for noise development | Replace, if necessary | |
| | | Check for oil loss | | |
| | | Check for true running (shaft-mounted geared motor) | | |
| Entire conveyor | Half-yearly | Check for soiling | Clean, if necessary | |
| Drive system (over drive) | Half-yearly | Check chain tension | Re-tighten if necessary | |
| Drive system (centre drive) | Half-yearly | Check for soiling | Clean, if necessary | |
| Flange bearing | Yearly | Check for smooth movement | Replace, if necessary | |
| | | Lubricating nipple | Lubricate | |
| Torque arm | Yearly | Check rubber buffer | Replace, if necessary | |

Troubleshooting

In case of malfunctioning



DANGER

Danger of death due to electric shock!

- Ensure that the conveyor has been de-energized before carrying out maintenance and repair work.
- Faults at electrical appliances should only be eliminated by qualified electricians!

Operators are only allowed to eliminate faults which are clearly related to an operator error! The danger zones at the conveyor are covered by guards and protective equipment.

- Stop the device immediately and ensure that it cannot be started accidentally.
- Remove the conveyed material.
- Always make sure that nobody can be injured before restarting the conveyor.
- Dispose of any leaked gear oil correctly. If necessary, a specialist must replace the geared motor.

Troubleshooting

| Symptom | Cause | Help |
|--|---|--|
| Transport cannot be started and geared motor is not running. | Main switch and/or control switched off | ➤ Check the switch position; if necessary, actuate the main switch and/or key-operated switch of the control |
| Transport cannot be started and geared motor is running. | Belt too loose | ➤ Re-tension the belt. |
| | Transport weight too high | ➤ Observe max. weight |
| Belt rubs against the side frame. | Belt adjustment is not straight | ➤ Adjust the belt to run straight |
| Protective motor switch is triggered by excessive power input. | Gearing defective, drive roller bearing defective | ➤ Replace defective part |
| | Short circuit | ➤ Check electrical connections and replace defective parts |
| | Excessive unit load weight | ➤ Observe max. weight |
| Noise development / squeaking / whistling | Bearings defective | ➤ Replace bearings |
| | Belt rubbing | ➤ Eliminate the source |

Spare and wear parts

Spare parts drawing for head drive type 4081.1

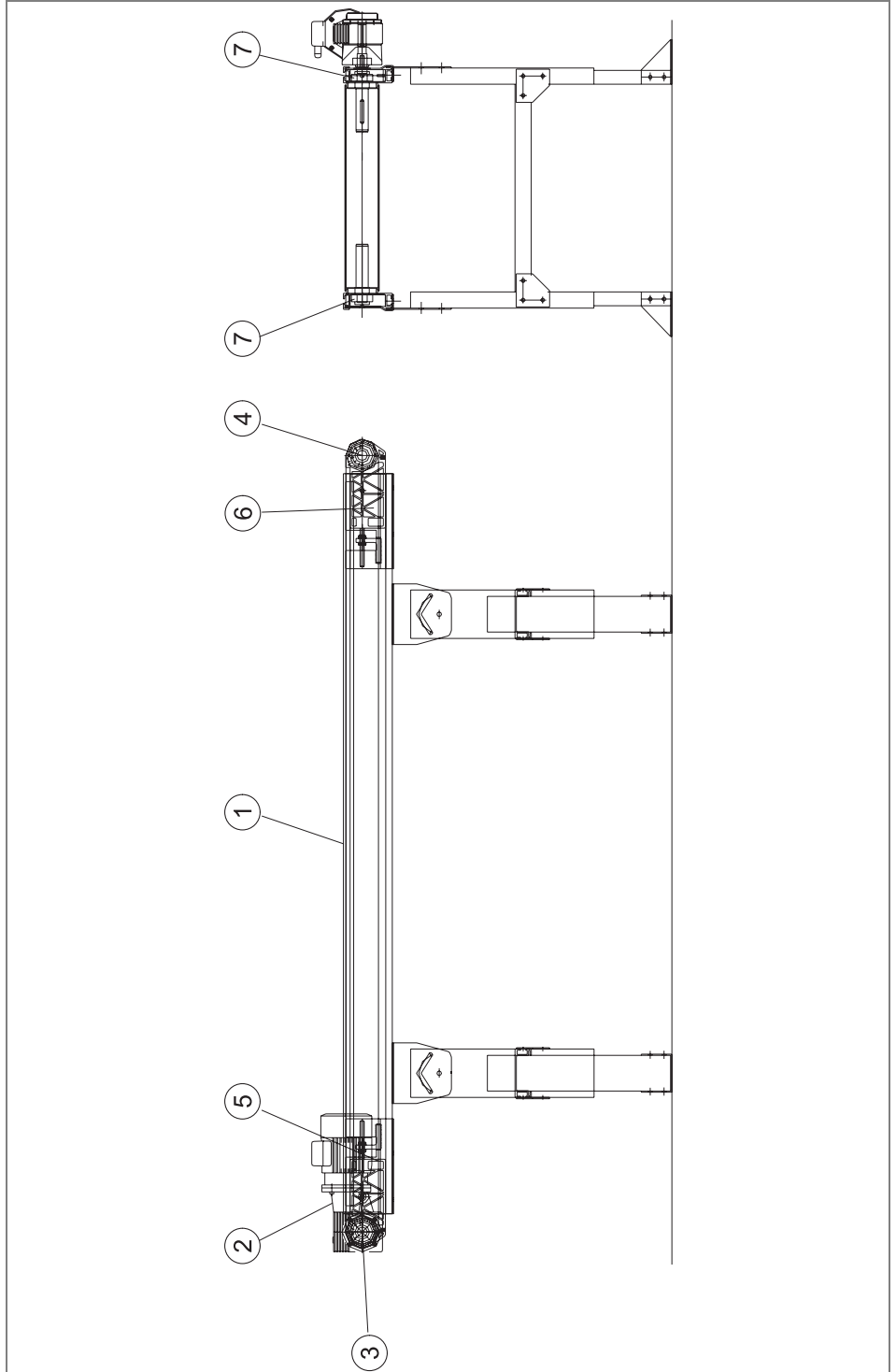

Spare and wear parts

Spare parts drawing for incline/decline conveyor type 4081.3

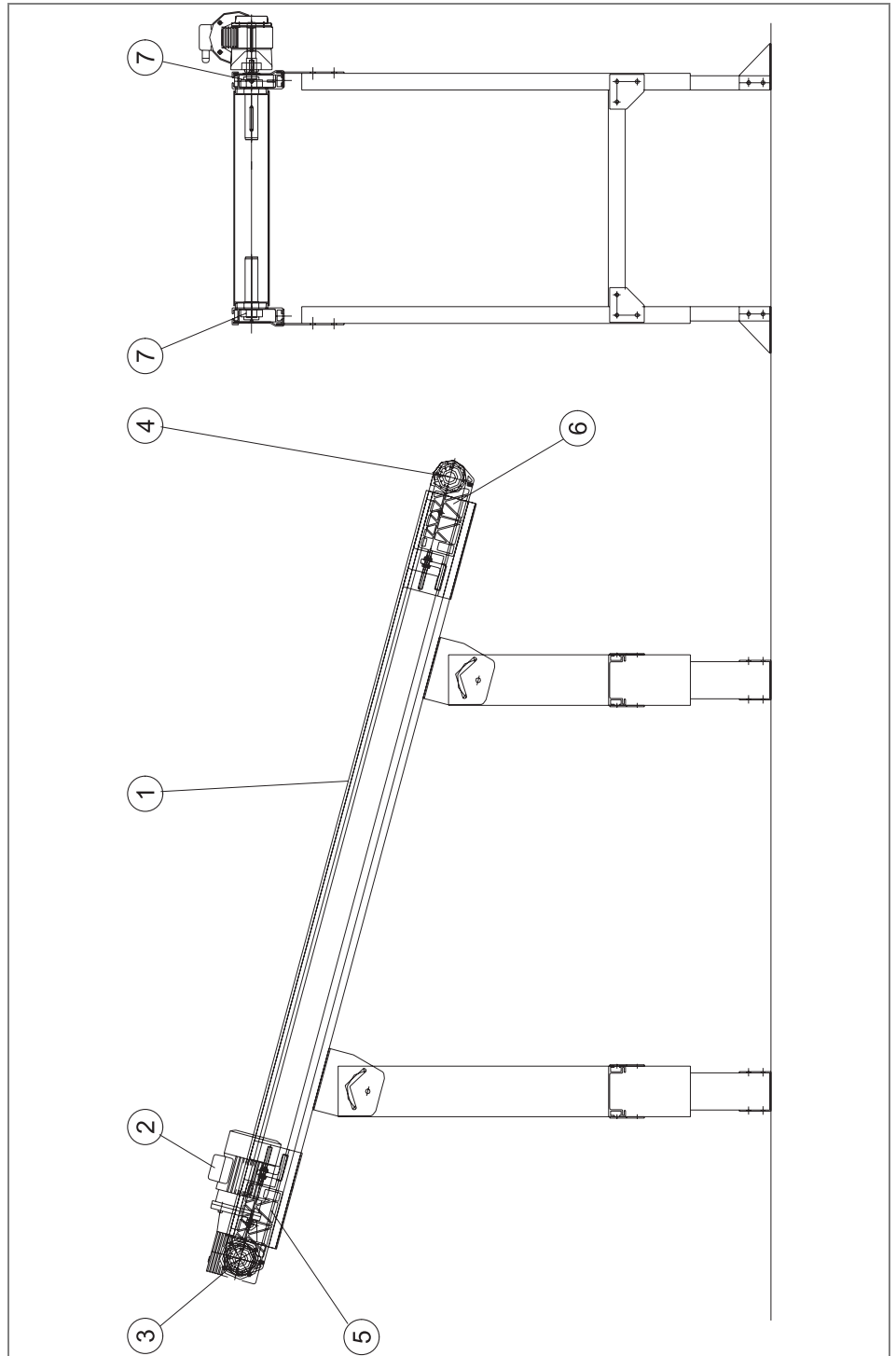

Spare and wear parts

Spare parts drawing for angled conveyor type 4081.4

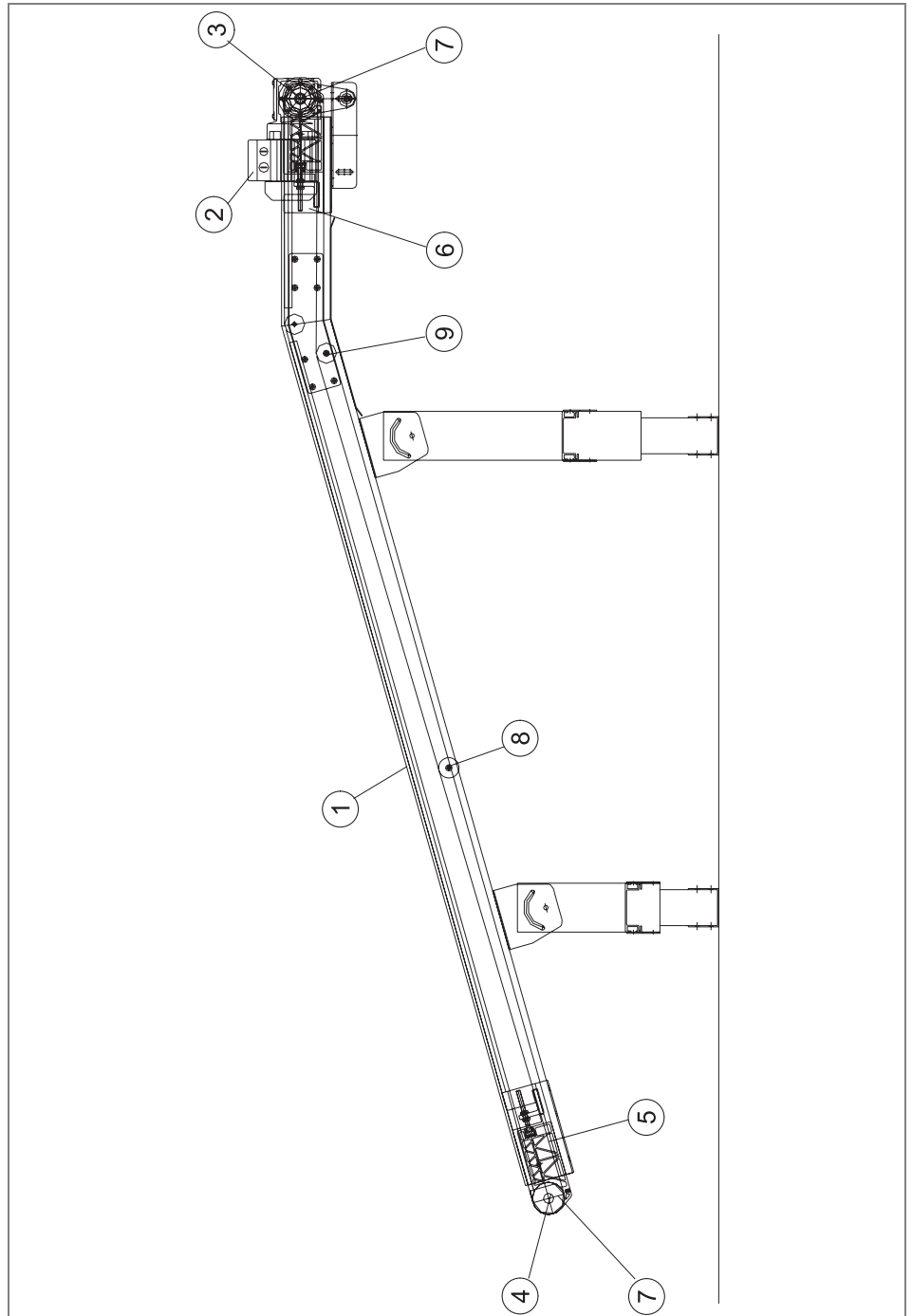

Spare and wear parts

Spare parts drawing for angled conveyor with power feeder/
outfeeder belt type 4081.6

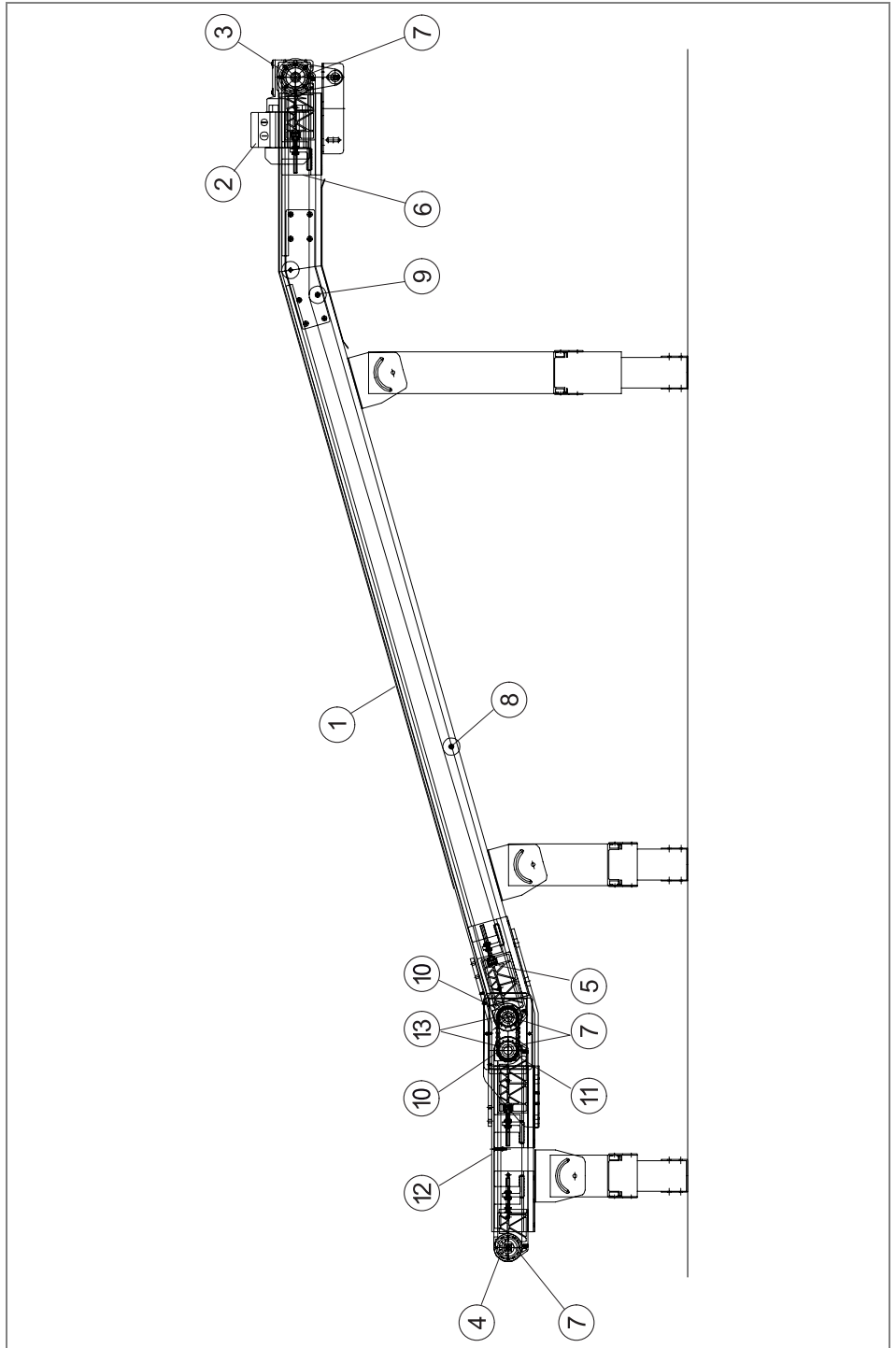

Spare and wear parts

Spare parts drawing for incline/decline conveyor with power feeder/outfeeder belt type 4081.8

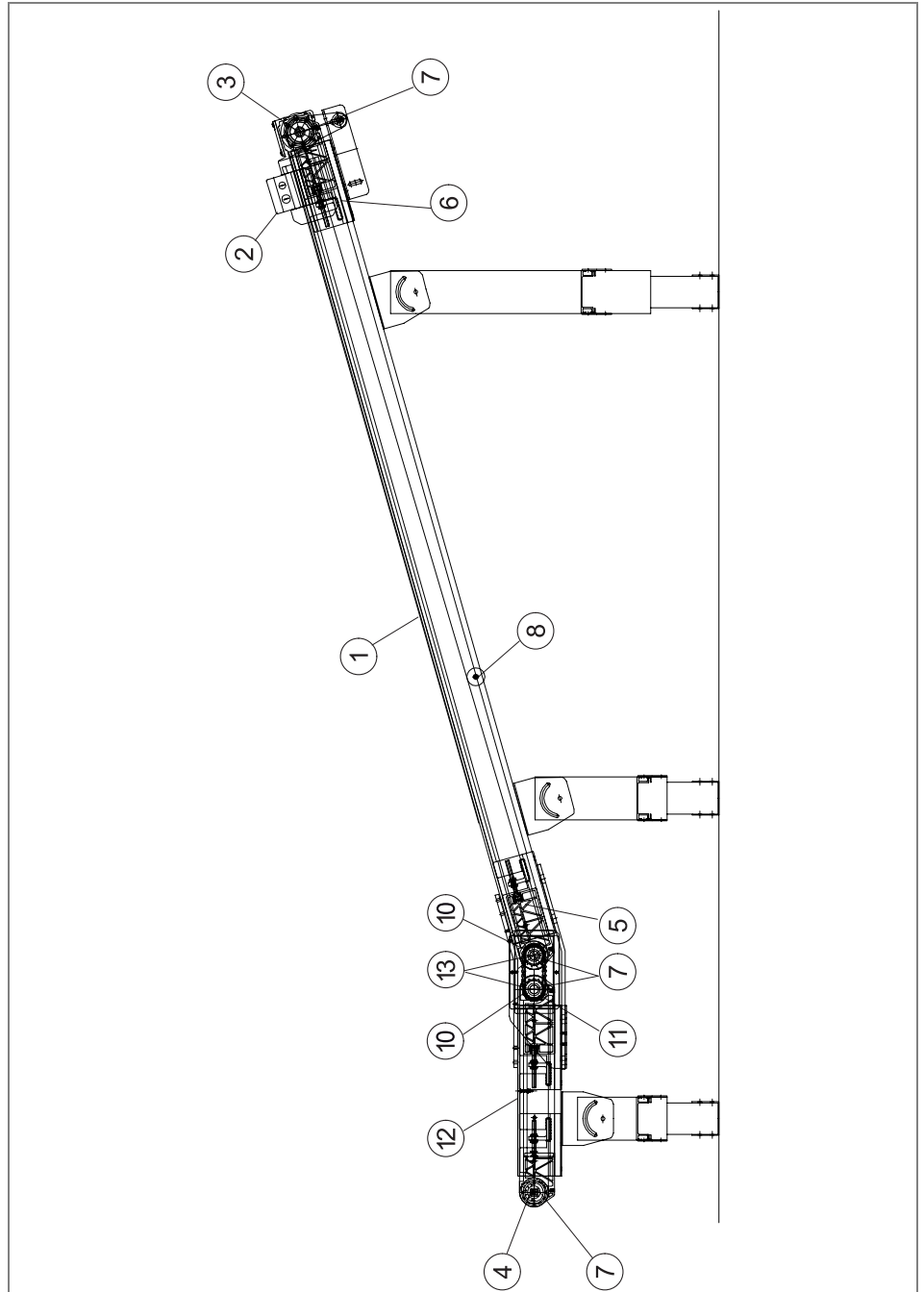

Spare and wear parts

Spare parts list types 4081.1, 4081.3, 4081.4, 4081.6 and 4081.8

Nrec.=Recommended number, S=Spare part, W=Wear part, T=Tool

| Mach. no.: | | Conveyor belt 11... | | |
|-------------------|--|--|--------------|--------------|
| Type: | | 4081 | | |
| Pos. no.: | Name | Comment | Nrec. | S/W/T |
| ① | Conveyor belt | 2-layer polyester belt with PVC cover or PU cover | 1 | S/W |
| ② | Shaft-mounted geared motor Belt drive | 3-phase; 400 V / 230 V; 50 Hz 3-phase; 400 V / 230 V; 50 Hz | 1 | S |
| ③ | Drive roller (shaft-mounted geared motor) | Ø80 mm, Ø92 mm, Ø120 mm, Ø132 mm | 1 | S |
| ④ | End roller | Ø20 mm, Ø40 mm, Ø80 mm, Ø92 mm, Ø120 mm | 1 | S |
| ⑤ | Bearing block (tensioning station) | Plastic part left | 1 | S |
| ⑥ | Bearing block (tensioning station) | Plastic part right | 1 | S |
| ⑦ | Spherical bearing (for bearing block) | 2205 E 2RS C3 | 2 | S/W |
| ⑧ | Belt contact pressure roller | Ø50 mm | 1 | S |
| ⑨ | Angled roller (type 4081.4 and type 4081.6) | Ø50 mm | 1 | S |
| ⑩ | Sprocket for over drive roller (type 4081.6 and type 4081.8) | 1/2" x 5/16" Z=14; d=20 (power feeder or outfeeder belt) | 1 | S/W |
| ⑪ | Chain | 1/2" x 5/16" | 1 | S/W |
| ⑫ | Conveyor belt (power feeder or outfeeder belt type 4081.6 and type 4081.8) | 2-layer polyester belt with PVC cover | 1 | S/W |
| ⑬ | Over drive roller (type 4081.6 and type 4081.8) | Ø80 mm | 1 | S |

Spare and wear parts

Spare parts drawing for centre drive type 4081.2

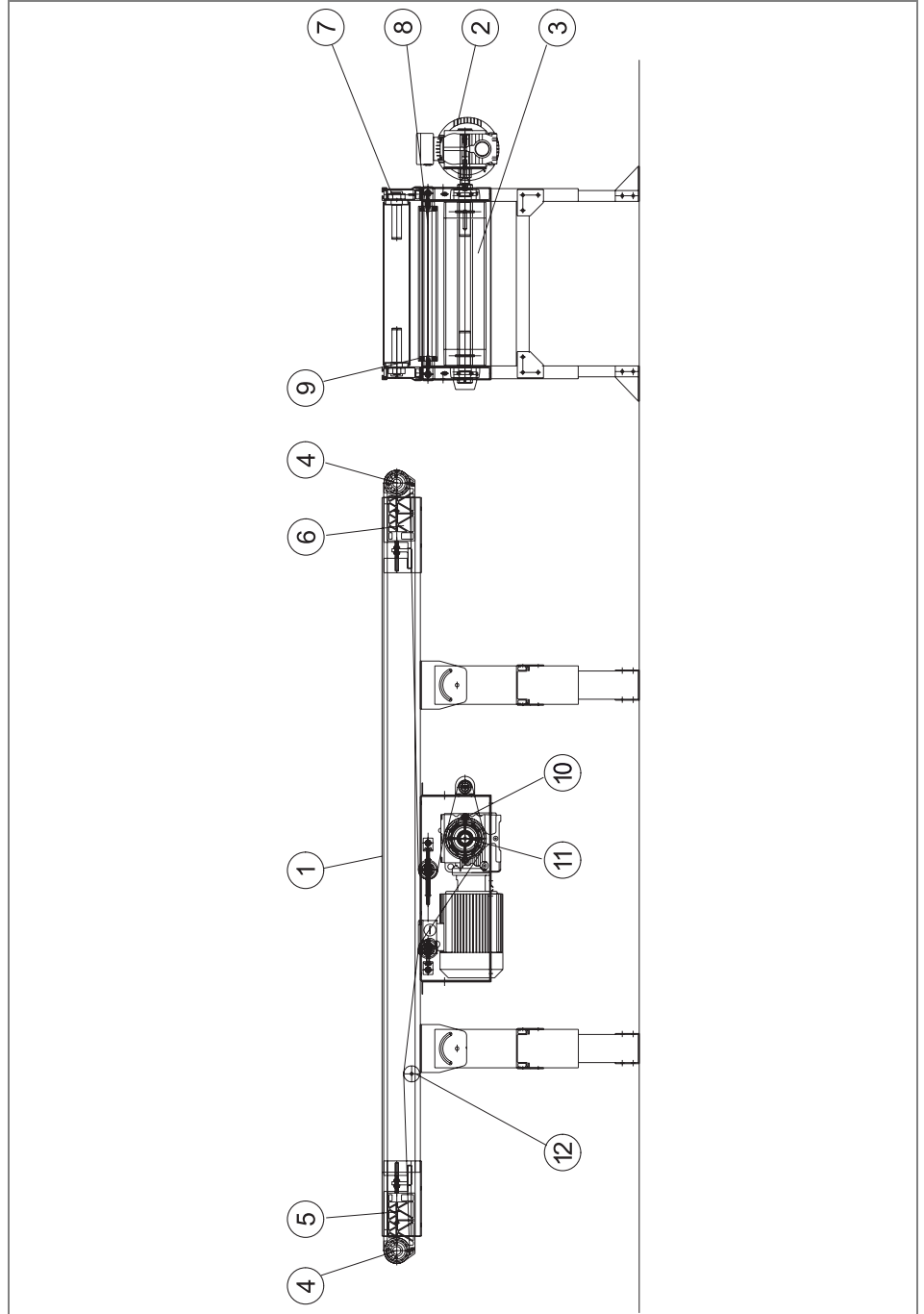

Spare and wear parts

Spare parts list for type 4081.2

Nrec.=Recommended number, S=Spare part, W=Wear part, T=Tool

| Mach. no.: | | Conveyor belt 11... | | |
|-------------------|--|---|--------------|--------------|
| Type: | | 4081 | | |
| Pos. no.: | Name | Comment | Nrec. | S/W/T |
| ① | Conveyor belt | 2-layer polyester belt with PVC cover or PU cover | 1 | S/W |
| ② | Shaft-mounted geared motor | 3-phase; 400 V / 230 V; 50 Hz | 1 | S |
| ③ | Centre drive roller | Ø92 mm, Ø120 mm, Ø132 mm | 1 | S |
| ④ | End roller | Ø20 mm, Ø40 mm, Ø80 mm, Ø92 mm, Ø120 mm | 1 | S |
| ⑤ | Bearing block (tensioning station) | Plastic part left | 1 | S |
| ⑥ | Bearing block (tensioning station) | Plastic part right | 1 | S |
| ⑦ | Spherical bearing (for bearing block) | 2205 E 2RS C3 | 2 | S/W |
| ⑧ | Tensioning roller complete (for centre drive) | Ø60 mm | 1 | S |
| ⑨ | Deep groove ball bearing (for tensioning roller) | 6205 2Z C3 | 2 | S |
| ⑩ | Flange bearing (for centre drive) | PCJTY 35 | 2 | S/W |
| ⑪ | Cover cap flange bearing | KA SK 07B | - | - |
| ⑫ | Belt contact pressure roller | Ø50 mm | 1 | S |

Spare and wear parts

Spare parts drawing for over drive type 4081.7

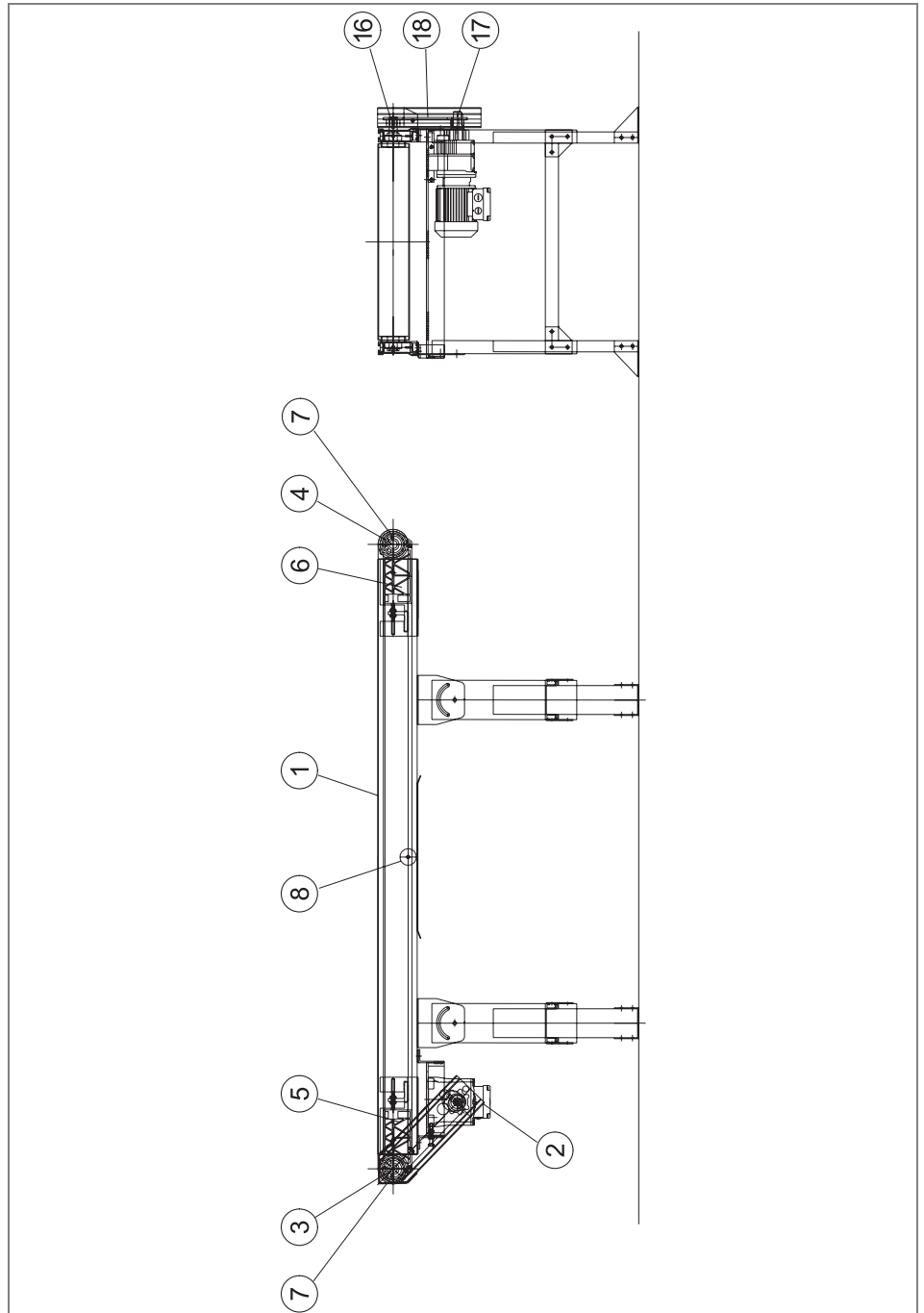

Spare and wear parts

Spare parts list for type 4081.7

| | | | |
|-------------------|--|---|--------------------|
| Mach. no.: | Conveyor belt 11... | | |
| Type: | 4081 | | |
| Pos. no.: | Name | Comment | Nrec. S/W/T |
| ① | Conveyor belt | 2-layer polyester belt with PVC cover or PU cover | 1 S/W |
| ② | Parallel shaft geared motor | 3-phase; 400 V / 230 V; 50 Hz | 1 S |
| ③ | Over drive roller | Ø80 mm, Ø92 mm, Ø120 mm | 1 S |
| ④ | End roller | Ø20 mm, Ø40 mm, Ø80 mm, Ø92 mm, Ø120 mm | 1 S |
| ⑤ | Bearing block (tensioning station) | Plastic part left | 1 S |
| ⑥ | Bearing block (tensioning station) | Plastic part right | 1 S |
| ⑦ | Spherical bearing (for bearing block) | 2205 E 2RS C3 | 2 S/W |
| ⑧ | Belt contact pressure roller | Ø50 mm | 1 S |
| ⑯ | Sprocket for over drive roller | 1/2" x 5/16" | 1 S/W |
| ⑰ | Sprocket for parallel shaft geared motor | 1/2" x 5/16" | 1 S/W |
| ⑱ | Chain | 1/2" x 5/16" | 1 S/W |



Spare and wear parts

Order details

Precise identification of the device is imperative when ordering spare and wear parts, see "*Product identification*", page 8.

The following information is required for an order:

- Machine number
- Type
- Position number of the spare parts list
- Name
- Comment
- Recommended number (Nrec.)
- It must be stated whether a spare part, wear part or tool (S/W/T) is required

Please contact your supplier for further information about the spare parts on offer.

Shut-down and disposal

Shut-down and disposal

- Adhere to the manufacturer's disposal documents when disposing of the motor oil.
- To protect the environment, recycle the packaging.

Environmental regulations

When working on and at the conveyor, always observe legal rules and regulations as regards waste avoidance, correct disposal and material recycling.



NOTICE

Ensure that materials which are hazardous to waters, such as grease, lubricants, hydraulic oil, coolants or solvent-based cleaning fluids, do not pollute the ground or enter the sewage system during operation!

- Always keep, transport, collect and dispose of these materials in suitable containers.
- Observe information about suitable storage containers.
- Adhere to further national regulations.



Manufacturer's declaration

According to EC Machinery Directive 98/37/EC and its amendment 98/79/EC, Appendix II B

The manufacturer:

Interroll Automation GmbH

Untere Au 4, D-74889 Sinsheim

hereby declares that the conveyor module described below:

- Mask.-nr./fabrikat: Interroll Belt Conveyor
- Type: 4081

is not a ready-to-use machine according to the EC Machinery Directive and, therefore, does not fully comply with the requirements of this directive. Initial start-up of these conveyor modules is not permitted until conformity of the entire machine/system in which they are installed has been declared via the EC Machinery Directive!

Applied EC directives:

Machinery Directive 98/37/EC with the amendment 98/79/EC

Low Voltage Directive 2006/95/EC

EMC Directive 2004/108/EC

Applied harmonized standards:

EN ISO 12100 Part 1 and Part 2

EN 294 "Safety of machinery, safety distances to prevent danger zones being reached"

EN 349 "Safety of machinery, minimum distances to avoid crushing"

EN 60204-1

Sinsheim, on

Dr.-Ing. Heinrich Droste

(Managing Director)







A U T O M A T I O N

Europe

Germany

Interroll Automation GmbH
Untere Au 4
D-74889 Sinsheim
Tel. +49 7261 938 10
Fax. +49 7261 938 124
automation@interroll.com

France

Interroll France SAS
SBU Automation
Z.I. de Kerannou – BP 34
F – 29250 Saint Pol de Léon
France
Tel. +33 682 5665 16
Fax. +33 298 244 102
f-sales@interroll.com

United Kingdom

Interroll Ltd.
Sales Office Automation
Brunel Road
Earlstress Industrial Estate
GB-Corby, Northants NN17 4UX
Tel. +44 1536 748,520
Fax. +44 1536 748 505
gb-automation@interroll.com

Spain

Interroll España S.A.
C.I. Santiga
C/Puig dels Tudons 5
E-08210 Barberà del Vallès
Tel. +34 93 729 96 50
Fax.+34 93 718 96 50
e-sales@interroll.com

North and South America

USA

Interroll Automation, LLC
4650 New Middle Road
Bridgeport Business Center
USA-Jeffersonville, IN 47130
Tel. +1 812 284-1000
Fax. +1 812 284-1001
usa-automation@interroll.com

Africa

South Africa

Interroll S.A. (Pty. Ltd.)
P.O. Box 327
Isando 1600
ZA-Gauteng
Tel. +27 11 974 1901
Fax. +27 11 974 1896
za-sales@interroll.com

Asia

China

Interroll (Suzhou) Co. Ltd.
Unit 10B, Modern Xian Dai
Industrial Square
No. 333 Xing Pu Road
Suzhou Industrial Park,
Jiangsu Province
Postal Code: 215126
People's Republic of China
Tel. +86 512 6256 0383
Fax. +86 512 6356 0385
cn-sales@interroll.com

Japan

Interroll Japan Co. Ltd.
302-1 Shimokuzawa
Sagamihara-shi
Kanagawa, Japan (229-1134)
Tel. +81 42 764 -2677
Fax. +81 42 764 -2678
jpn-sales@interroll.com

Singapore

Interroll (Asia) Pte. Ltd.
386 Jalan Ahmad Ibrahim
Singapore 629156
Republic of Singapore
Tel. +65 6266 6322
Fax. +65 6266 6849
sgp-sales@interroll.com

Thailand

Interroll (Thailand) Co. Ltd.
41/6 Moo 6, Bangchalong, Bangplee
Samutprakam 10540, Thailand
Tel. +66 2 337 01 88
Fax. +66 2 337 01 92
th-sales@interroll.com

South Korea

Interroll (Korea) Co. Ltd.
Rm 301, Dongsan Bldg. 333-60
Shindang-Dong
KR-Choong Ku, Seoul
Tel. +82 2 2231 19 00
Fax. +82 2 2254 36 83
kr-sales@interroll.com

www.interroll.com